

+GF+

COOL-FIT 2.0

Planning Fundamentals

Plan, Build, Operate

Design and Installation

COOL-FIT 2.0

Content

1	COOL-FIT 2.0	3
1.1	General Information	3
1.2	System Specification	4
1.3	Technical Details	6
1.4	Dimensioning and Design	20
1.5	Jointing and Installation	61
1.6	Transport, Handling and Storage	81
1.7	Environment	81

1 COOL-FIT 2.0

1.1 General Information

COOL-FIT 2.0 is a pre-insulated piping system for the delivery of secondary refrigerants. Thanks to its insulation thickness of 20 mm, the system can be used in air-conditioning systems with secondary refrigerant temperatures above 0 °C. COOL-FIT 2.0 is based on established, impact resistant and corrosion free PE pipe and fittings. The smooth inner surface of the fluid pipe provides minimal losses of pressure. The low thermal conductivity and high quality insulation guarantee low operating cost over the entire lifespan of the system. Thanks to the 3 in 1 design – Fluid pipe / Insulation / Jacket tube – installation time is kept very short.

The system consists of pipe, fittings, valves, flexible hoses and transition fittings. All components are pre-insulated or supplied with mountable insulation shells. The COOL-FIT 2.0 tools allow for fast and safe installation of the system.



The COOL-FIT 2.0 system is a completely pre-insulated plastic piping system for secondary refrigerant circuits run with water, brine, or Glycol based solutions.

The COOL-FIT 2.0 system is suitable for use in applications like:



Comfort Cooling

- Air conditioning
- Airports
- Apartments
- Hospitals
- Industrial buildings

Safe Cooling

- Data centers
- Hotels
- Shopping centers
- Sports center / leisure center
- Universities
- Bank / public institutions

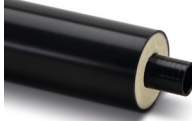
1.2 System Specification

Specification		COOL-FIT 2.0	COOL-FIT 2.0F	COOL-FIT 2.0 Push System
				
Materials ¹⁾	Pipe	PE100	PE100	Multilayer composite pipe PE-RT/Al/PE-RT
	Insulation	GF-HE foam, halogen free, closed-cell	GF-HE foam, halogen free, closed-cell	Pipe: EPDM foam Fitting: EPP foam
	Outer jacket	Pipe HDPE Fitting GF-HE	Flame retardant - GF-FR	Stainless steel polyester fabric TPE
Size ²⁾	d32DN25 – d140DN125	d32DN25 – d140DN125	d16DN12 - d32DN25	
Connection technology	Electrofusion	Electrofusion	Push-in connector	
Nominal pressure ³⁾	16 bar, SDR11	16 bar, SDR11	16 bar	
Temperature	Medium	0 °C bis +60 °C	0 °C bis +60 °C	+5 °C bis +60°C
	Environment	0 °C bis +55 °C	0 °C bis +55 °C	+0 °C bis +55°C
Insulation	Thermal conductivity $\lambda_{10^\circ\text{C}}$			
	PE Inner pipe	0.38 W/mK	0.38 W/mK	
	HE Foam	0.022 W/mK	0.026 W/mK	
	PE jacket	0.38 W/mK		
	GF-FR jacket		0.15 W/mK	
	Multilayer composite pipe			0.43 W/mK
	EPDM Foam			0.037 W/mK
Density	$\geq 70 \text{ kg/m}^3$	$\geq 70 \text{ kg/m}^3$	50-60 kg/m ³	
Foam cell size	max. \varnothing 0.5 mm	max. \varnothing 0.5 mm		
Nominal thickness	22 mm	22 mm	13 mm	
Mechanical strength (from insulation)	Axial shear strength	$\geq 0.12 \text{ N/mm}^2$	$> 0.12 \text{ N/mm}^2$	
	Compressive strength	$\geq 0.3 \text{ N/mm}^2$	$\geq 0.3 \text{ N/mm}^2$	
Colour	Outer jacket	Black	Black	Black
Weight (without medium)	Pipe d32	1.12 kg/m	1.06 kg/m	0.62 kg/m
	Pipe d110	5.5 kg/m	5.39 kg/m	
Oxygen diffusion at $\leq 5^\circ\text{C}$	ISO 17455	$\leq 0.083 \text{ mg}/(\text{m}^2 \text{ d})$	Oxygen diffusion tight acc. DIN 4726	Oxygen diffusion tight acc. DIN 4726
Fire classification ⁴⁾	EN 13501-1	E	B - s2, d0	C - s2, d0
Environment	Stability	Moisture and vapor-tight	Moisture and vapor-tight	Moisture and vapor-tight
	Weather/UV resistance	For indoor use	For indoor use	For indoor use
	Ozone Depletion Potential	Zero	Zero	Zero
Standards and Guidelines	DIN EN 12201-2	Plastics piping systems for water supply, and for drainage and sewerage under pressure - Polyethylene (PE)		
	ISO 7	Threaded Joints		
		Industrial valves ...		
	EN ISO 16135	– Ball valves made of thermoplastics		
	EN ISO 16136	– Butterfly valves made of thermoplastics		
	EN ISO 16137	– Backflow protection made of thermoplastics		
EN ISO 16138	– Diaphragm valve made of thermoplastics			
EN ISO 16871	Plastic piping and ducting systems – Plastic pipe and fittings – Method for exposure to direct (natural) weathering			
EN ISO 13501-1	Fire classification of construction products and building elements			

Product declarations		BNB BN 2015	
Green buildings		BREEAM Int 2016	
		DGNB 2015	
		DGNB 2018	
		LEED V3	
		LEED V4	
		WELL V1 2019	
eco-bau	(BKP 240, 244, 250)	eco 1	eco 2

- 1) All three materials are firmly bonded together. Does not apply to COOL-FIT 2.0 Push System.
- 2) Bigger dimensions available via COOL-FIT 4.0 and COOL-FIT 4.0F product range
- 3) At 20°C, medium water, the specified value is valid for all system components, with the exception of the butterfly valves, PN10 applies to the nominal pressure and for flexible hoses with maximum pressure according product datasheet.
- 4) Additional information in chapter "Fire behavior and fire prevention measures".

1.3 Technical Details

1.3.1 COOL-FIT 2.0

COOL-FIT 2.0 pipe

COOL-FIT 2.0 pipes are made from PE100. The high efficiency GF-HE hard foam insulation exhibits a thermal conductivity λ of 0.022 W/mK. The pipes are protected by a impact resistant PE jacket.

All three materials are firmly bonded in order to ensure good insulation properties and low thermal expansion or contraction for the system.

The pipes are available in 5 m lengths.



Pipe size (mm)	Inner Pipe d x e (mm)	Inner Pipe d _i (mm)	Outer jacket D x e1 (mm)	Weight empty (kg/m)	Weight with water (kg/m)	Volume (l/m)	Insulation thickness (mm)	Heat transfer coefficient (U) (W/m K)	Fire load (kWh/m)
d32/75	32 x 2.9	26.2	75 x 3	1.12	1.66	0.54	18.5	0.16	12.41
d40/90	40 x 3.7	32.6	90 x 3	1.50	2.34	0.83	22.0	0.17	16.55
d50/90	50 x 4.6	40.8	90 x 3	1.67	2.98	1.31	17.0	0.24	18.91
d63/110	63 x 5.8	51.4	110 x 3.4	2.47	4.54	2.07	20.1	0.25	27.91
d75/125	75 x 6.8	61.4	125 x 3.8	3.24	6.20	2.96	21.2	0.28	36.88
d90/140	90 x 8.2	73.6	140 x 4	4.17	8.43	4.25	21.0	0.32	47.91
d110/160	110 x 10	90.0	160 x 4	5.50	11.86	6.36	21.0	0.38	63.47
d140/200	140 x 12.7	114.6	200 x 5	8.71	19.02	10.31	25.0	0.47	100.88

d Nominal outer diameter of the PE pipe
 d_i Nominal inside diameter of the pipe
 D Nominal outside diameter of the outer PE jacket
 e, e1 Nominal wall thickness

COOL-FIT 2.0F pipe

COOL-FIT 2.0F inner pipe is made from PE100. The insulation made of highly efficient GF HE rigid foam has a thermal conductivity λ of 0.022 W/mK. The pipe is protected by the GF-FR fire retardant jacket.

All three materials are firmly bonded in order to ensure good insulation properties and low thermal expansion or contraction for the system.

The pipes are available in 5m lengths and can be connected with all fittings from COOL-FIT 2.0.

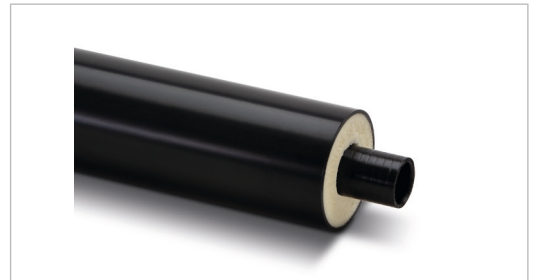

Pipe size (mm)	Inner Pipe d x e (mm)	Inner Pipe d _i (mm)	Outer jacket D x e1 (mm)	Weight empty (kg/m)	Weight with water (kg/m)	Volume (l/m)	Insulation thickness (mm)	Heat transfer coefficient (U) (W/m K)	Fire load (kWh/m)
d32/75	32 x 2.9	26.2	75 x 1.8	1.06	1.60	0.54	19.7	0.16	7.54
d40/90	40 x 3.7	32.6	90 x 1.8	1.43	2.27	0.83	23.2	0.17	10.65
d50/90	50 x 4.6	40.8	90 x 1.8	1.60	2.91	1.31	18.2	0.23	13.01
d63/110	63 x 5.8	51.4	110 x 1.8	2.27	4.34	2.07	21.7	0.24	19.20
d75/125	75 x 6.8	61.4	125 x 1.8	2.88	5.84	2.96	23.2	0.26	25.29
d90/140	90 x 8.2	73.6	140 x 2.5	4.09	8.34	4.25	22.5	0.30	35.87
d110/160	110 x 10	90.0	160 x 2.5	5.39	11.76	6.36	22.5	0.36	49.65
d140/200	140 x 12.7	114.6	200 x 2.5	8.05	18.37	10.31	27.5	0.44	76.84

d Nominal outer diameter of the PE pipe
 d_i Nominal inside diameter of the pipe
 D Nominal outside diameter of the outer PE jacket
 e, e1 Nominal wall thickness

COOL-FIT 2.0 fittings

General

The media fitting and insulation used for COOL-FIT 2.0 fittings fulfill the same specifications as the COOL-FIT 2.0 pipe. The COOL-FIT 2.0 fittings are based on ELGEF electrofusion fittings, which have been in use successfully for years. They provide an easy and safe connection.

The pre-insulated COOL-FIT 2.0 fittings are available in two types:

Type A:

Electrofusion fitting with integrated resistance wires for direct electrofusion pipe-to-fitting connections.



Reducer as an example

Type B:

Spigot fitting with free ends for pipe-to-fitting electrofusion with COOL-FIT 2.0 electrofusion fittings.



Reducer as an example

Usefull functions - Fittings type A:

Fusion indicators

After welding, check whether there is wear to the fusion indicators. After the welding process, the indicator pin shows clearly that energy has been applied to the welding zone.



Sealing lip

The sealing lip can be used to check whether the insulation has been properly sealed. If they bulge after the fitting has been pushed up to the end stop on the pipe, the installation is correct. By labelling the lip end on the pipe any changes in position of the fitting can be monitored.

For direct fitting-to-fitting or fitting-to-valve connections, the sealing lip can be removed beforehand during electrofusion fitting.



Label

The fittings have abrasion-resistant marking.



Trace code

Relevant product data can be traced back to production via traceability codes.



Angle marking

By marking the ends of the fittings, connections between pipe and fittings can be optimally aligned.



All Type A fittings feature a dome surrounding the welding connectors. It tops the outer diameter of a fitting, thus increases the total height (H) of a fitting in this specific section. The outer diameter of a fitting (D_{ist}) is slightly larger than the nominal outer diameter (D) of the system. See dimension table for Type A fittings:

d/D (mm)	D_{ist} (mm)	H (mm)
32/75	82	87
40/90	97	99
50/90	97	105
63/110	117	123
75/125	132	139
90/140	147	154
110/160	168	177
140/200	208	208

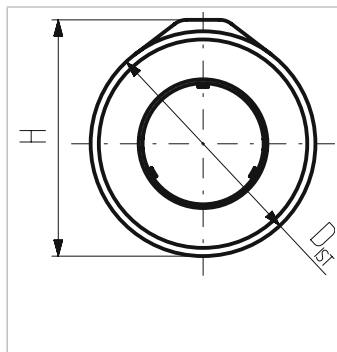

d/D Nominal inner- / outer diameter COOL-FIT 2.0 System
 D_{ist} Effective outer diameter fitting Type A
 H Fitting height at welding connector section

Joining

Pipe and Fitting

Type A fittings have integrated resistance wires, which are put under electric current during the welding operation through welding contacts on the fittings. This heats up the inside of the fitting and bonds the melting zone with the pipe.

Type B fittings feature non-insulated spigot ends. They are connected with electrofusion coupler to a pipe (see chapter below "components").

Fitting-to-fitting

Two COOL-FIT 2.0 fittings are usually connected by using a piece of COOL-FIT 2.0 pipe with free ends or a short piece of ecoFIT PE pipe and an insulation ring (e.g. ring removed with the foam removal tool). The shortest connection between two COOL-FIT 2.0 Type A fittings can be achieved by cutting off the sealing lips and using a barrel nipple and an adhesive ring for the vapor seal (see components).

Two COOL-FIT 2.0 Type B fittings can be joined using an electrofusion coupler (see components).

The connection of a COOL-FIT 2.0 fitting Type A and Type B is also possible.

Components

Fittings can be connected to either pipe or other fittings using the parts described below:

COOL-FIT 2.0 Electrofusion coupler

COOL-FIT 2.0 electrofusion couplers are used to connect pipe and components with free ends like type B fittings, valves and transition fittings.



COOL-FIT 2.0 Elbows 45° and 90°

(Refer to „General“ chapter above)



COOL-FIT 2.0 T90° equal and COOL-FIT T90° reduced

The equal and reduced type A 90° tees have, like the coupler, resistance wires for electrofusion. The central outlets can be connected to the type A fitting, so all combinations are possible.



COOL-FIT 2.0 reducer

The COOL-FIT 2.0 reducer can be used to reduce the flow of the starting size by up to three to four sizes (e.g. from d140 up to d63 or from d75 up to d32).



Combination of T90° and Reducer

If a reduction step should be done after the branch of a T90°, either a COOL-FIT 2.0 T90° reduced, or a COOL-FIT 2.0 T90° reduced/ equal connected to a reducer should be used.

Run Branch	40	50	63	75	90	110	140
32	Δ	Δ	Δ	Δ	Δ	Δ	0
40		X	X	0	0	0	0
50			X	0	0	0	0
63				Δ	Δ	Δ	Δ
75					Δ	Δ	Δ
90						Δ	Δ
110							Δ

- X T90°- equal + reducer
- 0 T90°- reduced + reducer
- Δ T90°- reduced

COOL-FIT 2.0 barrel nipple

COOL-FIT 2.0 barrel nipple serves as a compact direct connector for type A fittings.

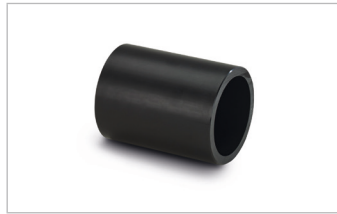

COOL-FIT 2.0 Sliding coupler kit

The sliding coupler kit is a radially insertable element for connecting two fixed pipe spigots.



Accessories

Insulation for fusion contacts

Supplied with each fitting. Prevent formation of a cold bridge at the fusion contacts. Insulation parts can also serve as an indicator that a connection has been welded (Install insulation after welding to show that the welding has been completed).



Adhesive ring

With a compact connection with a barrel nipple (fitting-to-fitting), this adhesive ring is used to ensure that the connection is water and vapor tight after the removal of the sealing lip.



Cement

For frontal bonding of the insulations of transition fittings and flexible hoses



Adhesive tape

Optional for covering hand-cut faces.



Sealant

The silicone-free sealant is used to join the EPDM insulation of Weld-in ports to the COOL-FIT pipes.



Y-Cable kit for COOL-FIT Fixpoints

Cuts the welding time by 50% and includes the required welding adapters.

Article no.: 790 156 032.



Tangit Rapid cement

Cement and cement gun for attaching the COOL-FIT 2.0F fixed point sets to the outer casing of the pipe.



COOL-FIT 2.0 valves

COOL-FIT 2.0 valves are based on GF standard plastic valves. The valves are supplied including GF-HE insulation shells with a protective PE jacket. The sealing faces between the shells and the valve are vapor tight by their design. No additional tape or sealant is required.



Releasable plastic bands for sizes d32DN25 – d63DN50 and metal straps with tension locks for sizes d75DN65 – d140DN125 permit the pre-insulated shells to be fitted to and removed from the valves easily, allowing easy maintenance.



The insulated ball valve in PVC-U is available in sizes d32DN25 – d90DN80, and the butterfly valve in sizes d110DN100 – d140DN125. Manual versions or such ISO 5211 interface are available. The interface is suitable for electric actuators from GF as well as for 3rd party actuators, e.g. Belimo.

Interfaces:

F03 and F05 for ball valves d32DN25 – d63DN50

F07 for all ball- and butterfly valves d75DN65 – d90DN80

Belimo actuators

The following Belimo actuators are compatible with our COOL-FIT 2.0 valves.

SR..-R type

- Actuator for COOL-FIT 2.0 ball valve type 546 Pro, bare shaft, DN25 to DN50
- F05 interface with square turned 45°: wrench size 11mm / shaft projection 11mm
- Required torque: max. 20Nm
- Torque of actuator: 20Nm

Actuator	Adapter	Nominal voltage	Control	Emergency function	Duration	Class	Auxiliary switch
SR230A-R	ZSV-11	AC 100...240 V	Open/close, 3 point	No	90 s / 90°	IP 54	No
SR230P-R	ZPV-11	AC 100...240 V	Open/close, 3 point	No	90 s / 90°	IP 66/67	No
SR230P-SR-R	ZPV-11	AC 230 V	Continuous	No	90 s / 90°	IP 66/67	No
SR24A-MF-R	ZSV-11	AC/DC 24 V	Continuous	No	90 s / 90° (veränderbar 90...350 s)	IP 54	No
SR24A-MP-R	ZSV-11	AC/DC 24 V	Continuous, MP-Bus	No	90 s / 90° (veränderbar 90...350 s)	IP 54	No
SR24A-R	ZSV-11	AC/DC 24 V	Open/close, 3 point	No	90 s / 90°	IP 54	No
SR24P-MF-R	ZPV-11	AC/DC 24 V	Continuous	No	90 s / 90° (changeable 90...350 s)	IP 66/67	No
SR24P-MP-R	ZPV-11	AC/DC 24 V	Continuous, MP-Bus	No	90 s / 90° (changeable 90...350 s)	IP 66/67	No
SR24P-R	ZPV-11	AC/DC 24 V	Open/close, 3 point	No	90 s / 90°	IP 66/67	No
SR24P-SR-R	ZPV-11	AC/DC 24 V	Continuous	No	90 s / 90°	IP 66/67	No
SRF24A-R	ZSFV-11	AC/DC 24 V	Open/close	Yes	75 s / 90°	IP 54	No
SRF24A-S2-R	ZSFV-11	AC/DC 24 V	Open/close	Yes	75 s / 90°	IP 54	2 x EPU
SRFA-R	ZSFV-11	AC 24...240 V / DC 24...125 V	Open/close	Yes	75 s / 90°	IP 54	No
SRFA-S2-R	ZSFV-11	AC 24...240 V / DC 24...125 V	Open/close	Yes	75 s / 90°	IP 54	2 x EPU

GR..-R type

- Actuator for COOL-FIT 2.0 ball valve type 546 Pro, DN65 and DN80
- F07 interface with square turned 45°: wrench size 11mm / shaft projection 27mm
- Required torque: max. 21Nm (DN65) / max. 35Nm (DN80)
- Torque of actuator: 40Nm

Actuator	Adapter	Nominal voltage	Control	Emergency function	Duration	Class	Auxiliary switch
GR230A-R	ZGV-16 + ZGI-004	AC 100.240 V	Open/close	No	150 s / 90°	IP 54	No
GR24A-MF-R	ZGV-16 + ZGI-004	AC/DC 24 V	Continuous	No	90 s / 90° (changeable 75...270 s)	IP 54	No
GR24A-MP-R	ZGV-16 + ZGI-004	AC/DC 24 V	Continuous, MP-Bus	No	90 s / 90° (changeable 75...270 s)	IP 54	No
GR24A-R	ZGV-16 + ZGI-004	AC/DC 24 V	Open/close	No	150 s / 90°	IP 54	No

Note: For DN65: motorization with 20 Nm via special interface on request

PR.. type

- Actuator for COOL-FIT 2.0 butterfly valve kit type 567, bare shaft, DN100
- F07 interface with square turned 45°: wrench size 14mm / shaft projection 16mm
- Required torque: max. 160Nm
- Torque of actuator: 160Nm

Actuator	Adapter	Nominal voltage	Control	Emergency function	Duration	Class	Auxiliary switch
PRCA-BAC-S2-T	ZPR06	AC 24...240 V / DC 24...125 V	Continuous, BACnet MS/TP, Modbus RTU, MP-Bus	No	35 s / 90° (changeable 30...120 s)	IP 66/67	2 x EPU
PRCA-S2-T	ZPR06	AC 24...240 V / DC 24...125 V	Open/close, 3 point	No	35 s / 90° (changeable 30...120 s)	IP 66/67	2 x EPU
PRKCA-BAC-S2-T	ZPR06	AC 24...240 V / DC 24...125 V	Continuous, BACnet MS/TP, Modbus RTU, MP-Bus	Yes (selectable position 0...100%)	35 s / 90° (changeable 30...120 s)	IP 66/67	2 x EPU

SY4.. type

- Actuator for COOL-FIT 2.0 butterfly valve kit type 567, bare shaft, DN125
- F07 interface with square turned 45°: wrench size 14mm / shaft projection 16mm
- Required torque: max. 200Nm
- Torque of actuator: 400Nm

Actuator	Adapter	Nominal voltage	Control	Emergency function	Duration	Class	Auxiliary switch
SY4-230-3-T	ZSY-005	AC 230 V	Open/close, 3 point	No	21 s / 90°	IP67	2 x EPU
SY4-230-MF-T	ZSY-005	AC 230 V	Continuous	No	16 s / 90°	IP67	2 x EPU
SY4-230-MP-T	ZSY-005	AC 230 V	Continuous, MP-Bus	No	16 s / 90°	IP67	2 x EPU
SY4-230-SR-T	ZSY-005	AC 230 V	Continuous	No	16 s / 90°	IP67	2 x EPU
SY4-24-3-T	ZSY-005	AC/DC 24 V	Open/close, 3 point	No	30 s / 90°	IP67	2 x EPU
SY4-24-MF-T	ZSY-005	AC/DC 24 V	Continuous	No	23 s / 90°	IP67	2 x EPU
SY4-24-MP-T	ZSY-005	AC/DC 24 V	Continuous, MP-Bus	No	23 s / 90°	IP67	2 x EPU
SY4-24-SR-T	ZSY-005	AC/DC 24 V	Continuous	No	23 s / 90°	IP67	2 x EPU

SY4.. type

- Actuator for COOL-FIT 4.0 butterfly valve kit type 567, DN150 and DN200 (for use in chilled water applications from 0°C - 60°C)
- F07 interface with square turned 45°: wrench size 17mm / shaft projection 19mm
- Required torque: max. 360Nm
- Torque of actuator: 400Nm

Actuator	Adapter	Nominal voltage	Control	Emergency function	Duration	Class	Auxiliary switch
SY4-230-3-T	ZSY-013	AC 230 V	Open/close, 3 point	No	21 s / 90°	IP67	2 x EPU
SY4-230-MF-T	ZSY-013	AC 230 V	Continuous	No	16 s / 90°	IP67	2 x EPU
SY4-230-MP-T	ZSY-013	AC 230 V	Continuous, MP-Bus	No	16 s / 90°	IP67	2 x EPU
SY4-230-SR-T	ZSY-013	AC 230 V	Continuous	No	16 s / 90°	IP67	2 x EPU
SY4-24-3-T	ZSY-013	AC/DC 24 V	Open/close, 3 point	No	30 s / 90°	IP67	2 x EPU
SY4-24-MF-T	ZSY-013	AC/DC 24 V	Continuous	No	23 s / 90°	IP67	2 x EPU
SY4-24-MP-T	ZSY-013	AC/DC 24 V	Continuous, MP-Bus	No	23 s / 90°	IP67	2 x EPU
SY4-24-SR-T	ZSY-013	AC/DC 24 V	Continuous	No	23 s / 90°	IP67	2 x EPU

COOL-FIT 2.0 transition fittings, flange connectors

Transition fittings and flange connectors enable connections to different systems in either metal or plastic, such as the Georg Fischer systems iFIT or Sanipex MT. All listed components are supplied with insulation in NBR foam:



Thread type/connector/ pitch circle	Size	Material	Thread type/connector/ pitch circle
Transition fittings for metal*	d32 – d63 ½" – 2 ¾"	PE – stainless steel PE – brass	Male thread (R), Female thread (Rp), Loose union nut (G)
Transition fittings to iFIT or Sanipex MT*	d32 1"	Stainless steel Brass	iFIT, Sanipex MT
Union plastic - plastic*	d32 – d110 1" – 4"	PE – PE, PE – ABS	Welding spigots Cementing socket
Adaptor union to metal*	d32 – d63 1" – 2"	PE – stainless steel	Internal thread (Rp), External thread (R)
Flange joints**	d32 – d140	PE	Bolt circle PN 10/16

* NBR foam insulation
** Insulation half shells similar to valve insulations

COOL-FIT 2.0 flex hoses

The flexible hose in EPDM with stainless steel protection permit mobile access to devices such as fancoils, compensating for expansion or contraction within the system. The tear-resistant protective tissue jacket and NBR insulation (19mm, $\lambda_{10^\circ\text{C}} \leq 0.036 \text{ W/mK}$) ensure the temperature of the cooling medium remains unchanged. Versatile connectivity options mean that system connection is ensured: G thread (external thread + loose nut)



d (mm)	DN (mm)	Thread	Length (mm)	Max. compensation ΔL (mm)	R_{min} (min. bending radius) (mm)
20	15	½"	1'000	276	119
25	20	¾"	1'000	161	156
32	25	1"	1'000	68	192
40	32	1 ¼"	1'500	233	252
50	40	1 ½"	2'000	396	312
63	50	2"	2'000	233	372

COOL-FIT 2.0 Installation fittings type 313

Installation fittings are used to install various types of sensors to the system. Pressure or temperature sensors can be connected using the 1/2" or 3/4" Rp female thread. The insulation is comprised of highly efficient GF-HE foam with excellent insulating capabilities.



COOL-FIT 2.0 Fixed point

The fixed point is used to direct pipe movement or retain forces from pipe weight at risers. The electrofusion welding tapes allow a permanent connection and transmit occurring forces between pipe and clamp.



COOL-FIT 2.0 Fixed point for high forces

The fixpoint placed on the media pipe allows the transmission of higher forces. The fixed point is placed between two electrofusion fittings.



COOL-FIT 2.0 Weld-In Port

The COOL-FIT Weld-in port significantly increases the flexibility by enabling the branching-off on already laid, unfilled and dry COOL-FIT pipes in dimensions d63-d225. The product range of fittings includes Weld-in ports with transitions to female threads, as well as Weld-in ports that allow transitions within the GF piping portfolio. The EPDM soft foam insulation supplied with the Weld-in ports is designed to ensure a condensation-free connection to the COOL-FIT pipe, and to insulate the nipples up to the corresponding interface.



Connection type, material	Size	Purpose
Female thread Rp, PE/Brass	1/2", 3/4", 1"	Installation of instruments, probes, sensors as well as transition to other piping systems
iFIT, PE/Brass	16/20, 25/32	Transition from COOL-FIT 2.0 and COOL-FIT 4.0 to COOL-FIT 2.0 Push System
Sanipex MT, PE/Brass	32	Transition from COOL-FIT 2.0 and COOL-FIT 4.0 to GF Sanipex MT
PE spigot SDR11	32, 40, 50	Connection within COOL-FIT 2.0 and COOL-FIT 4.0

The Weld-in ports can be used with pipes COOL-FIT 2.0, COOL-FIT 2.0F, COOL-FIT 4.0 and COOL-FIT 4.0F

Jointing

After the controlled local tapping of jacket and inner pipe of the respective COOL-FIT pipe, the welded joint is made.

In the cone welding process used here, a modified version of heating element socket welding, the inner pipe of the COOL-FIT pipe and the Weld-in port are welded in an overlapping material-to-material bond without the use of additional filler materials.

The welding surfaces of the pipe and the fitting are heated to welding temperature on a conical socket- or spigot-shaped heating element and then joined together.

The dimensionally matched geometry of the components ensures the welding pressure during joining and a homogeneous joint.

Jointing principle

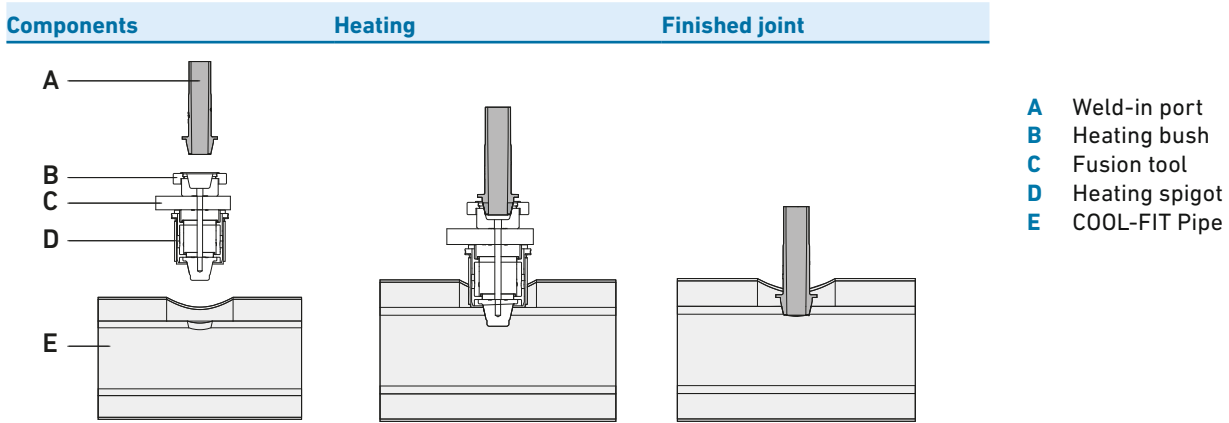

After the fusion process, the EPDM insulation is mounted to the Weld-in port. Bonding of insulation the COOL-FIT pipe is done using the COOL-FIT sealant.

Distance of COOL-FIT Weld-in ports and pressure de-rating of main pipes

On positioning the Weld-in ports on the COOL-FIT pipe, the following distances must be taken into account:

- Distances between Weld-in ports along the pipe axis.
- Arrangement around the circumference of the pipe.

	Ports with metal insert	Ports with PE spigot
Distances along pipe axis* 	$x \geq 120 \text{ mm}$ ► no pressure de-rating of main pipe	$x \geq 2 * d$ main pipe ► no pressure de-rating of main pipe or $x < 2 * d$ main pipe ► pressure de-rating factor of main pipe of 0.8
Arrangement around circumference 	$x \geq 0 \text{ mm}$ (along pipe axis), $\alpha \geq 60^\circ$ ► no pressure de-rating of main pipe	

* The minimum distance due to the tool dimensions is 120 mm.

Heigh of Weld-in ports 1/2"-1" towards the pipe axis

Heigh h1 [mm]/d [mm]	d63	d75	d90	d110	d140	d160	d225
1/2" Rp	117	123	130	140	155	165	198
3/4" RP	117	123	130	140	155	165	198
1" Rp	118	124	131	141	156	166	199

1.3.2 COOL-FIT 2.0 Push System

COOL-FIT 2.0 Push System pipe

Inside the multilayer composite pipes of the COOL-FIT 2.0 push system is a medium-bearing layer made of polyethylene (PE-RT). The outer layer, which protects the pipe from mechanical loads, is also made of PE-RT. In between is a longitudinally butt-welded aluminum carrier pipe, which is permanently bonded to the other two layers by means of bonding agents - also PE-based.

The EPDM insulation has a thermal conductivity of 0.037W/mK at 10°C and is covered with an additional polyester/stainless steel mesh, which prevents wrinkling and protects the pipe from mechanical stress.

The pipes are available in 5m rod and 25m roll.

Pipe size	Inner Pipe	Inner Pipe	Outer jacket	Weight empty	Weight with water	Volume	Insulation thickness	Heat transfer coefficient (U)	Fire load	Bending radius R with spring	Bending radius R with tool
(mm)	d x e (mm)	d _i (mm)	D x e ₁ (mm)	(kg/m)	(kg/m)	(l/m)	(mm)	(W/m K)	(kWh/m)	5x d (mm)	3,5 x d (mm)
d16/44	16 x 2	12	44 x 1	0.299	0.412	0.113	13	0.20	0.93	80	56
d20/48	20 x 2	16	48 x 1	0.354	0.556	0.201	13	0.23	1.13	100	70
d25/54	25 x 2.5	20	54 x 1	0.521	0.836	0.314	13.5	0.26	1.60	200	98
d32/61	32 x 3	26	61 x 1	0.621	1.152	0.523	13.5	0.31	2.28		112

- d Nominal outer diameter of the PE pipe
- d_i Nominal inside diameter of the pipe
- D Nominal outside diameter of the outer jacket
- e, e₁ Nominal wall thickness

COOL-FIT 2.0 Push System Fittings

General

The Push System fittings are made of high-performance polyphenylsulfone (PPSU) plastic. This material has proven itself for fittings in building services and is characterized above all by excellent corrosion resistance and low incrustation. The Push System fittings have a high degree of robustness, i.e. special impact strength and impact resistance.

To further increase mechanical strength, the iFIT adapters are additionally protected by a glass-fiber-reinforced polyamide (PA-GF30).

The insulation half-shells supplied fit onto the Push System fittings and can be closed quickly and easily with integrated tabs and hooks.



Connection

The connection is made using adapter module technology, a push system that requires few tools and no electrical power. It is possible to work across dimensions via the module.

The adapters are pushed onto the tube and module. A viewing window and "click" sounds allow the correct assembly to be checked during the installation process.

Push fitting

An iFIT tool is used for the processing and it is done manually. The iFIT push fitting guarantees a secure, fast and detachable connection. The modules are reusable. The adaptors can only be used once. This also applies to adaptors if the clicking action was not completed.

An iFIT push fitting consists of several components:

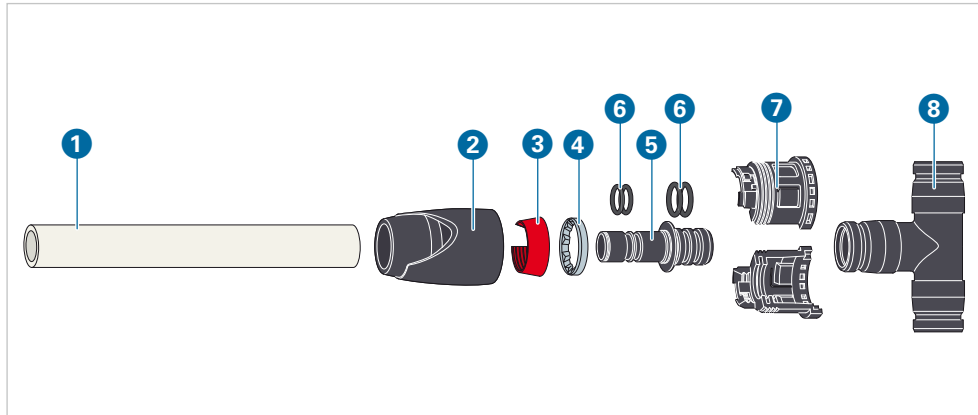

iFIT push fitting

1 Multilayer pipe

Adaptor

2 Adaptor housing

3 Clamping ring

4 Toothed ring

5 Insert

6 O-rings (EPDM)

7 Half shells

8 Module made of PPSU or low-lead, dezincification-resistant brass

The iFIT adaptor is plugged into a chamfered pipe end. The push fitting is then closed by clicking the module into the adaptor.

Inadmissible system connections

! **NOTE! Damage due to inadmissible system connections!**
 → When using the COOL-FIT 2.0 Push System, use only multilayer composite pipes from the COOL-FIT 2.0 Push System or iFIT assortment.

Components

COOL-FIT-2.0 Push System coupler

The sockets are used for straight connection of pipes.



COOL-FIT 2.0 Push System 90° elbow

The 90° elbows can be used to change the direction of the pipe when space is limited and it is not possible to bend the pipe.



COOL-FIT 2.0 Push System, T90° equal and T90° reduced

The T90° equal and T90° reduced are supplied with two adapters and compression rings only. At the outlet, a choice can be made between two dimensions in any case. Additional adapters must be ordered separately.



COOL-FIT 2.0 Push System reducer

By means of the COOL-FIT 2.0 Push System reducer, the flow of the output dimension can be reduced by up to 2 dimensional sizes.



COOL-FIT 2.0 Push System ball valve

The ball valves suitable for the COOL-FIT 2.0 Push System can be connected directly to the pipe via the adapters through a push fitting connection.



COOL-FIT 2.0 Push System flow control valve

The COOL-FIT 2.0 Push System volume flow controller, based on the TacoSetter, can be used to balance a wide variety of systems such as fan coils.



COOL-FIT 2.0 Transition fitting PE/iFIT

The COOL-FIT 2.0 transition fitting PE/iFIT provides a direct connection option from COOL-FIT 2.0 to the COOL-FIT 2.0 Push System.



1.3.3 COOL-FIT tools

Electrofusion machines

Electrofusion machines are required to join COOL-FIT 2.0 components. The range includes dedicated and multipurpose electrofusion machines which are reliable and easy to use.

GF recommends: MSA-Series electrofusion machines.



Foam removal tool and peeling tool – manually operated

The foam removal tool is used to prepare shortened COOL-FIT 2.0 / 2.0F pipe for electrofusion. The tool removes the foam and cuts outer jacket, and also peels the surface of the inner pipe. Any oxide layer present is removed when the welding zone is treated. The tool is available in two versions:

1. for sizes d32 – d90,
2. for sizes d110 – d140.

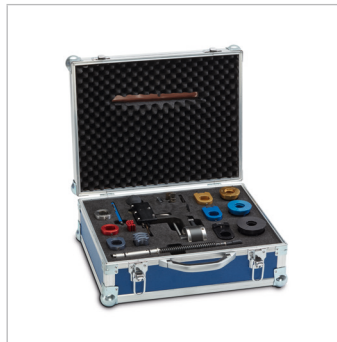

Clamping tool

The fusion process gives rise to forces that can pull the pipe out of the coupler. Therefore it is recommended that the assembly should be fitted with COOL-FIT installation clamps. This prevents movement during the welding- and cool-down process.

The central hinge allows the use of the clamps on elbows and reducers. Depending on the length of the pipe, 2 or 4 of the glass-reinforced plastic holders can be used. The linkage is made of galvanized steel. Tension bands are included and a T-adaptor is optional available.

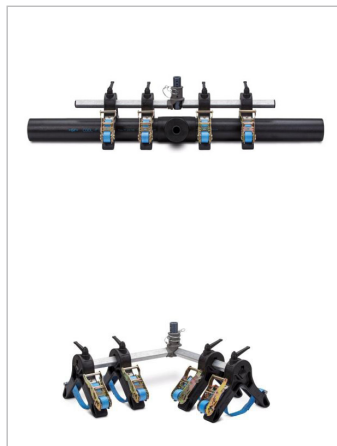

Weld-In Port installation tool

Using the installation tool, the different COOL-FIT Weld-in ports can be installed safe, reliable, reproducible and quick. Drilling of jacket, drilling of inner pipe as well as the subsequent welding joint is supported in a clever way. Depending on the need in Weld-in ports to be installed, the tool is available in 230V as well as in 110V in different equipment variants.

**iFIT tool set**

iFIT tool set enables a fast and safe installation of COOL-FIT 2.0 Push System components.



1.4 Dimensioning and Design

The following section describes only the COOL-FIT specific planning fundamentals. For prevailing information see general GF Planning Fundamentals.

1.4.1 General information about the dimensioning and installation of plastic piping

Plastics have different physical characteristics to metals. When designing and installing thermoplastic piping systems, this needs to be taken into account. Although PE and COOL-FIT 2.0 are very robust systems, care should be taken to avoid damage during handling and transportation.

For over 50 years, GF Piping Systems has developed and sold a variety of plastic piping systems which are subjected to very rigorous demands, such as optimized insulation properties in cooling applications. Experience has shown that plastic provides an economical and reliable alternative to metal when designers and installers take account of the recommendations in the technical documentation. In the professional production of plastic piping systems, for example, piping systems must be able to move to accommodate changes in length caused by temperature and pressure changes. To allow for these changes in length, the use of pipe holders that permit this movement is vital.

The following technical information contains the basic information needed to ensure an economical and trouble-free installation. However, this chapter does not contain all of the details. For more information, or if you have specific questions, please contact your local GF Piping Systems representative. Additional information is available on the official GF Piping Systems website.

1.4.2 COOL-FIT 2.0 pressure-temperature diagram

The pressure resistance for thermoplastic pipe for water is always specified at +20 °C. At higher temperatures allowance must be made for a lower maximum operating pressure.

The graphs show the maximum permissible pressure for COOL-FIT 2.0 pipe, fittings and valves at various temperatures, up to the maximum permissible media temperature of +60 °C. The table is based on an ambient temperature of +20 °C. A safety factor of 1.6 and a minimum lifespan of 25 years have been allowed for in all calculations.

Pressure/temperature limits for COOL-FIT 2.0 fittings, pipe, valves – water coolant

Limits for COOL-FIT 2.0: 25-year values allowing for the safety factor (with water as the coolant).

i In case of long-term operating pressure at temperatures above 47 °C, please contact your authorized GF Piping Systems representative.

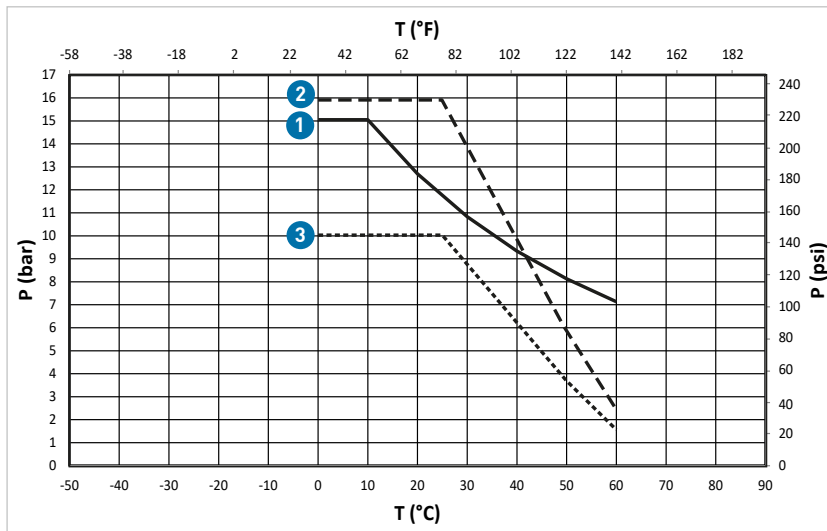

- P Allowable pressure (bar, psi)
- T Temperature (°C, °F)
- C Safety factor
- 1** COOL-FIT pipe and fitting
C=1.6, SDR11
- 2** COOL-FIT 2.0 ball valve
PN16
- 3** COOL-FIT butterfly valve
PN10

The butterfly valves used for the COOL-FIT 2.0 system exhibit lower pressure-temperature ratings than the rest of the components. If valves are used, it is necessary to refer to the data in the diagram above.

Pressure/temperature limits for COOL-FIT 2.0 Push System fittings, pipe, valves – water coolant

Limits for COOL-FIT 2.0: 25-year values (with water as the coolant).

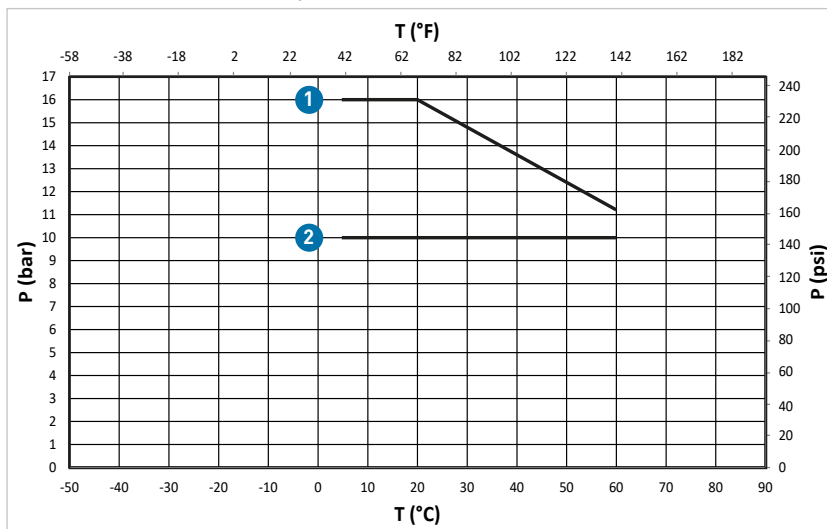

- P Allowable pressure (bar, psi)
- T Temperature (°C, °F)
- 1** COOL-FIT 2.0 Push System
pipe, fitting and ball valve
- 2** COOL-FIT 2.0 Push System
Flow control valve

Influence of secondary refrigerants with antifreeze additives

At ambient temperatures below 0 °C, antifreeze must be used in the water to prevent it from freezing during a plant shut-down.

COOL-FIT 2.0 is generally resistant to secondary coolants such as glycol and brines. For some secondary coolants a reduction factor is necessary depending on the type and mixing ratio. The permissible operating pressure is corrected downwards from the pressure-temperature curve for water.

Reduction factors¹

Inorganic salt solutions	F = 1
Organic salt solutions	F = 1
Glycol solutions (max. 50 %)	F = 1.1

For the calculation, the following formula is used:

¹ Valid for materials HD-PE, EPDM, PVC-U, metals

$$P_{AF} = \frac{P_w}{AF}$$

P_{AF}	Permissible pressure with reduction factor
P_w	Permissible pressure for water
AF	Reduction factor

Glycol solutions

COOL-FIT 2.0 / 2.0F can be used with glycol solutions with concentrations up to 50%. The chemical resistance of COOL-FIT 2.0 systems is suitable for the following antifreeze types:

Brand name	Hersteller	Typ
Antifrogen N	Clariant	Ethylene glycol
Antifrogen L	Clariant	Propylene glycol
Showbrine Blue Showa standard EG brine	Showa Brine	Ethylene glycol
Showbrine Blue Showa trial EC brine	Showa Brine	Ethylene glycol
Tyfocor L	Tyfo	Propylene glycol
Tyfocor	Tyfo	Ethylene glycol
DOWFROST	DOW	Propylene glycol
Zytrec FC	Arteco	Propylene glycol
Zytrec LC	Arteco	Propylene glycol
Zytrec MC	Arteco	Propylene glycol
Neutrogel Neo	Climalife Dehon	Ethylene glycol
Friogel Neo	Climalife Dehon	Propylene glycol
DOWTHERM SR-1	DOW	Ethylene glycol

When using other coolants, compatibility with COOL-FIT 2.0 should be clarified with GF Piping Systems.



Example – glycol dissolved in water

For water-glycol mixture ≤ 50%, the reduction factor for the pressure-temperature diagram is 1.1. Thus, at +10 °C, with a minimum life of 25 years, the maximum allowable working pressure is reduced as follows:

$$P_{AF} = \frac{15 \text{ bar}}{1.1} = 13.6 \text{ bar}$$

Organic salt solutions

These media are usually potassium formates or potassium acetates: aqueous solutions with low viscosity at low temperatures. COOL-FIT 2.0 can be used with the media below. The manufacturer's instructions must be followed.

Brand name	Manufacturer	Type
Antifrogen KF	Clariant	Brine
Zytrec S-55	Frigol	Brine
Temper	Temper	Brine
Hycool	Addcon	Brine

i For detailed information on resistance and reduction factors, see Planning Fundamentals "Material selection – Chemical resistance".

1.4.3 Polyethylene (PE)

The dominant material for the COOL-FIT 2.0 / 2.0F system is polyethylene (PE). As the inner pipe which comes into contact with the media is made of PE100, its properties are of particularly high relevance.

Properties of PE (approximate)

Property	PE 100-value ¹	Unit	Testing standard
Density	0.95	g/cm ³	EN ISO 1183-1
Yield stress at 23 °C	25	N/mm ²	EN ISO 527-1
Tensile modulus at 23 °C	900	N/mm ²	EN ISO 527-1
Charpy notched impact strength at 23 °C	83	kJ/m ²	EN ISO 179-1/1eA
Charpy notched impact strength at -40 °C	13	kJ/m ²	EN ISO 179-1/1eA
Crystallite melting point	130	°C	DIN 51007
Thermal conductivity at 23 °C	0.38	W/m K	EN 12664
Water absorption at 23 °C	0.01 - 0.04	%	EN ISO 62
Color	9,005		RAL
Oxygen Index (LOI)	17.4	%	4589-1

¹ Typical, measured on material characteristics, should not be used for calculations.

General information

All polymers made from hydrocarbons of the formula C_nH_{2n} are constructed with a double bond (ethylene, propylene, butene-1, isobutene) are referred to collectively as polyolefins. Among them is polyethylene (PE). It is a semi-crystalline thermoplastic. Polyethylene is probably the best known plastic. The chemical formula is: -(CH₂-CH₂)_n. PE is a non-polar material. Therefore, it is insoluble and scarcely swellable in conventional solvents. PE pipe cannot therefore be adhesively bonded to fittings. Welding is the appropriate connection method for the material.

In industrial piping, high molecular weight types have resulted in medium to high density. The types are classified by their creep rupture strength into PE80 (MRS 8 MPa) and PE100 (MRS 10 MPa). The latter are also called 3rd generation types of PE, while PE80 types are primarily associated with the 2nd generation. There are barely any first generation PE types – PE63 under the modern classification – remaining on the market. Creep rupture strength has been tested by long-term tests as per ISO 1167, and calculated in accordance with ISO 9080. The most widespread in piping system construction is PE for use in underground gas and water pipe. In this area polyethylene has become the dominant material in many countries. However, the advantages of this material mean that it is also used in domestic installations and industrial piping.

Advantages of PE

- Light weight
- Excellent flexibility
- Good wear resistance (abrasion resistance)
- Corrosion resistance
- Ductile fracture properties
- High impact strength even at very low temperatures
- Very good chemical resistance
- Weldable

Mechanical properties, chemicals, weathering and abrasion resistance

Chemical resistance

Polyethylene exhibits good resistance to a wide range of media. For detailed information, please see the detailed chemical resistance list from GF Piping Systems, or contact the person responsible at GF Piping Systems directly.



Abrasion resistance

PE has excellent resistance to abrasive wear. You can therefore find PE piping systems in use in numerous applications for transporting solids and media containing solids. For many applications, PE has proven especially advantageous with metals.



Thermal properties and electrical properties

Operating limits

The application limits of the material depend on both embrittlement and softening temperatures and on the manner and method of application. Details are provided in the relevant pressure-temperature charts.



Electrical properties

Polyethylene, like most thermoplastics, is non-conductive. This means that systems in PE do not suffer from electrolytic corrosion. However, the non-conductive properties must be taken into consideration, as electrostatic charges can build up in the pipe. Polyethylene has good electrical insulation properties. The volume resistance is $3.5 \times 10^{16} \Omega\text{cm}$, the surface resistance $10^{13} \Omega$. This must be taken into account in applications where there is danger of fire or explosion.



1.4.4 Fire behavior and fire prevention measures

Firestop classes

Classification of fire behavior

Construction materials are classified into different firestop classes depending on their fire behavior. The classification is decisive for whether specific materials may be legally used for construction in certain areas of construction projects.

European classification according to EN 13501-1

In the year 2001, the EN 13501-1 was introduced, a European classification system for construction materials. EN 13501-1 defines 6 construction material classes from A to F:

A	No contribution to the development of a fire (A1, A2)
B	Very little contribution to the development of a fire
C	Limited contribution to the development of a fire
D	Acceptable contribution to the development of a fire
E	Acceptable fire behavior
F	No performance criteria detected

In addition to the fire behavior, the European standard also rates fire side effects: smoke release (s1, s2, s3) and burning droplets (d0, d1, d2).

Smoke release:

s1	limited smoke release
s2	average smoke release
s3	high smoke release, or smoke release not tested

Burning droplets:

d0	no burning droplets/fall off within 600 seconds
d1	no burning droplets/fall off with an afterglow time of more than 10 seconds within 600 seconds
d2	No performance criteria detected

Fire prevention classes EN13501-1, VKF and British building codes

	COOL-FIT 2.0	COOL-FIT 2.0F	COOL-FIT 2.0 Push System	COOL-FIT 2.0/ mineral wool ²
				
EN 13501-1	E	B – s2, d0	C – s2, d0	A2 _L
BS 5422:2009 ¹	National Class 3			National Class 0

¹ Test method according to BS 476-6 and BS 476-7
² Type: Rockwool 800

Thermal load

The thermal load corresponds to a thermal potential (energy release) related to a specific base area, fire section area in m², for example an escape route. The physical unit for the thermal load is energy per surface area kWh/m². The calculative thermal load is equivalent to the sum of the different thermal potentials of all used combustible used elements, such as pipelines. When the energy released per running meter of the pipe (kWh/m) is known, the thermal load of the pipe is calculated from the used pipe length.

d/D (mm)	32/75	40/90	50/90	63/110	75/125	90/140	110/160	140/200
Thermal load COOL-FIT 2.0 pipes (kWh/m)	12.02	15.97	18.43	29.38	36.84	46.93	62.32	99.14

d/D (mm)	32/75	40/90	50/90	63/110	75/125	90/140	110/160	140/200
Thermal load COOL-FIT 2.0F pipes (kWh/m)	7.54	10.65	13.01	19.20	25.29	35.87	49.65	76.84

d/D (mm)	16/44	20/48	25/54	32/61
Thermal load COOL-FIT 2.0 Push System pipes (kWh/m)	0.93	1.13	1.60	2.28

Fire resistance of components

While the fire behavior characterizes individual materials, the fire resistance must be considered for entire assemblies, for example a solid wall with pipe penetrations. The fire resistance is equivalent to the amount of time in which a component maintains its function during a standard fire.

The European system allows classification according to different criteria, stating the respective fire resistance duration in minutes.

Fire resistance and classification according to the European standards

Pipe insulation systems are exposed to a standard fire according to EN 1363-3. Classification is according to EN 13501-2 and generally includes the criteria integrity (E, Étanchéité) and thermal insulation (I, Insulation).

Abbreviation	Criterion	Rating
E – Étanchéité	Flame protection or integrity	Measurement of an element's capacity of preventing the passage of gases and flames in case of fire.
I – Insulation	Insulation or thermal insulation	Measurement of the insulation capacity of an element, i.e. the duration in which the side of the element facing away from the fire does not exceed 180° C + the ambient temperature.

Firestop collars/Fire sealing

When pipes are installed through fire-rated assemblies, whose reliable functioning must not be affected, firestop collars that comply with local requirements and legislation must be used.

Hilti firestop

System description

The firestop collar (incl. fastening hook) is made of galvanized steel sheet into which strips of intumescent material (i.e. that swells in case of fire) are inserted.

The fire retardation sealing with straight pipes is regulated in conjunction with the following products in the individual countries:

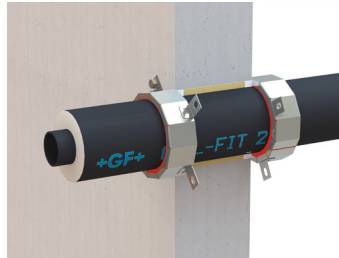

Product	Proof of applicability	Countries
Hilti firestop collar CP 644	Allgemeine Bauartgenehmigung (aBg) Z-19.53-2330	DE
Hilti firestop collar CP 644	VKF Technische Auskunft 14108	CH
Hilti firestop collar CFS-C P	ETA-10/0404	EU

The respective details of the proofs of application must be taken into account.

Additional information is available at Hilti online or from your Hilti contact person.

Hilti CP 644	Hilti CFS-C P
Info Shop	Info Shop
	
qr.hilti.com/r3069	qr.hilti.com/r4831

The following applications are regulated via the above proofs of application:

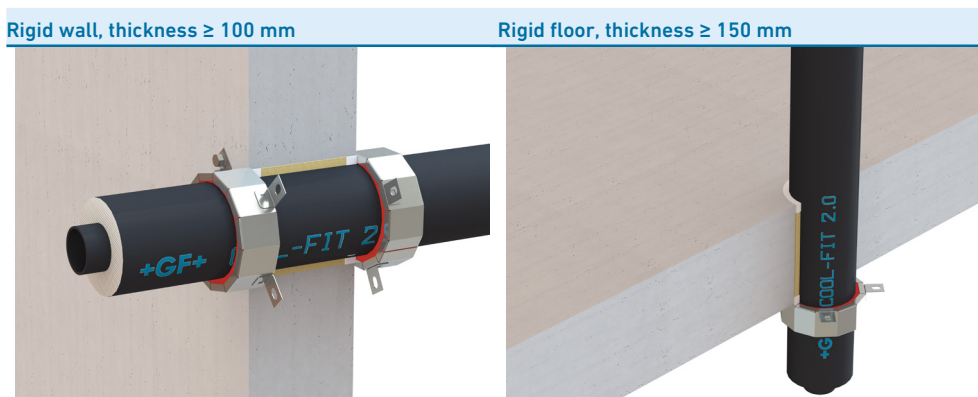

Fire-retarding sealing

COOL-FIT 2.0 pipes up to and including an outside diameter D of 200mm, can be sealed in rigid walls and rigid floors by a Hilti firestop collar.

Rigid wall ≥ 100mm solid		Product DE, CH	Product EU	Fire resistance	Mounting
d (mm)	D (mm)	CP 644	CFS-C P		Number of hooks
32	75	CP 644-75/2.5"	CFS-C P 75/2.5"	EI 120-U/C	3
40	90	CP 644-90/3"	CFS-C P 90/3"	EI 120-U/C	3
50	90	CP 644-90/3"	CFS-C P 90/3"	EI 120-U/C	3
63	110	CP 644-110/4"	CFS-C P 110/4"	EI 120-U/C	4
75	125	CP 644-125/5"	CFS-C P 125/5"	EI 120-U/C	4
90	140	CP 644-160/6"	CFS-C P 160/6"	EI 120-U/C	6
110	160	CP 644-160/6"	CFS-C P 160/6"	EI 90-U/C	6
140	200	CP 644-200/8"	CFS-C P 200/8"	EI 120-U/C*	8

Rigid floor ≥ 150mm solid		Product DE, CH	Product EU	Fire resistance	Mounting
d (mm)	D (mm)	CP 644	CFS-C P		Number of hooks
32	75	CP 644-75/2.5"	CFS-C P 75/2.5"	EI 120-U/C	3
40	90	CP 644-90/3"	CFS-C P 90/3"	EI 120-U/C	3
50	90	CP 644-90/3"	CFS-C P 90/3"	EI 120-U/C	3
63	110	CP 644-110/4"	CFS-C P 110/4"	EI 120-U/C	4
75	125	CP 644-125/5"	CFS-C P 125/5"	EI 90-U/C	4
90	140	CP 644-160/6"	CFS-C P 160/6"	EI 120-U/C	6
110	160	CP 644-160/6"	CFS-C P 160/6"	EI 120-U/C	6
140	200	CP 644-200/8"	CFS-C P 200/8"	EI 60-U/C*	8

* here exclusively gap sealing with non-combustible construction materials

Annular gap sealing

For the installation situations there are several options for sealing gaps against smoke gas.

Gap sealing with non-combustible construction materials:

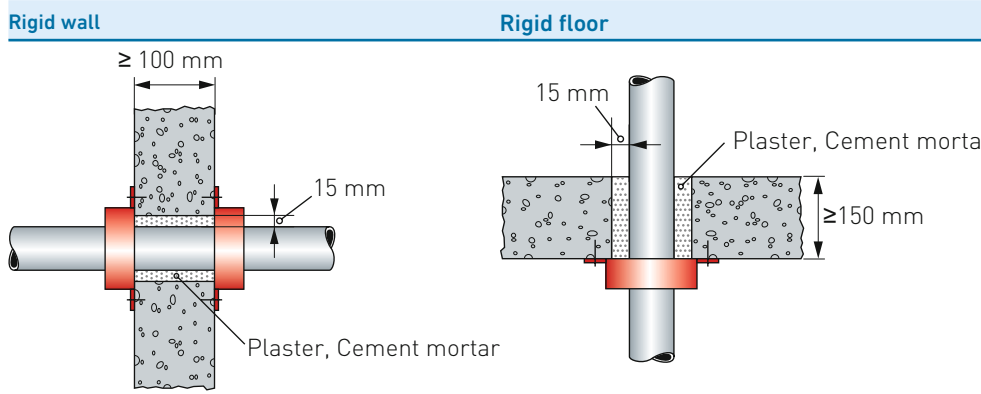

Joint closure with Hilti firestop sealant CFS-S ACR and mineral wool backfill up to 15mm annular gap width for Hilti firestop collar CP 644 and CFS-C P.

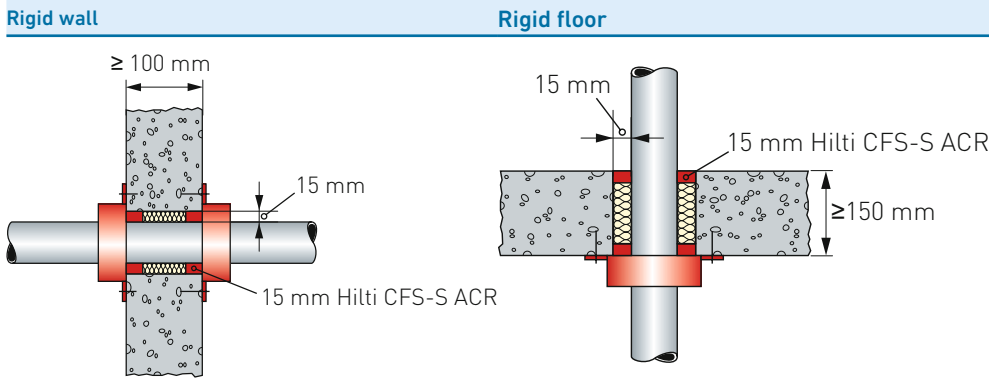

Distance regulations

The distance of the component openings to be closed to other openings or installed elements must comply with the data provided in the following table.

Distance of the pipe sealing to	Size of the adjacent openings	Distance between the openings DE, CH	Distance between the openings EU
Other cable or pipe sealing	one/both openings > 40cm x 40cm	≥ 20cm	≥ 20cm
	Both openings ≤ 40cm	≥ 10cm	
Other openings or installed elements	one/both openings > 20cm x 20cm	≥ 20cm	≥ 20cm
	Both openings ≤ 20cm	≥ 10cm	

The following pipe distances between the openings of the pipe lead through are derived from this for pipe sealing with the Hilti firestop collar for COOL-FIT 2.0:



Shaft installation

A shaft installation with additional pipelines, for example for heating and drinking water, may look as follows:

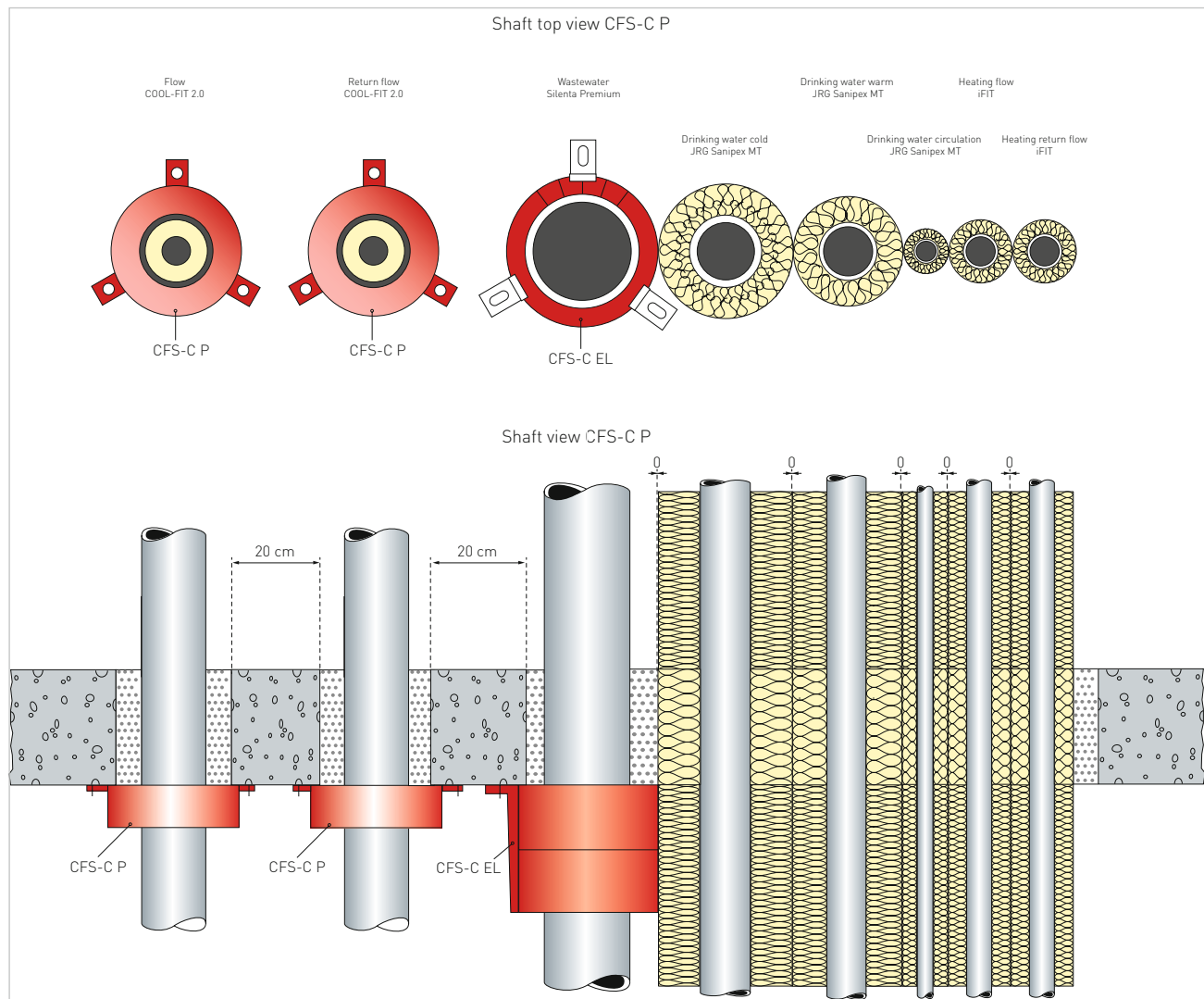

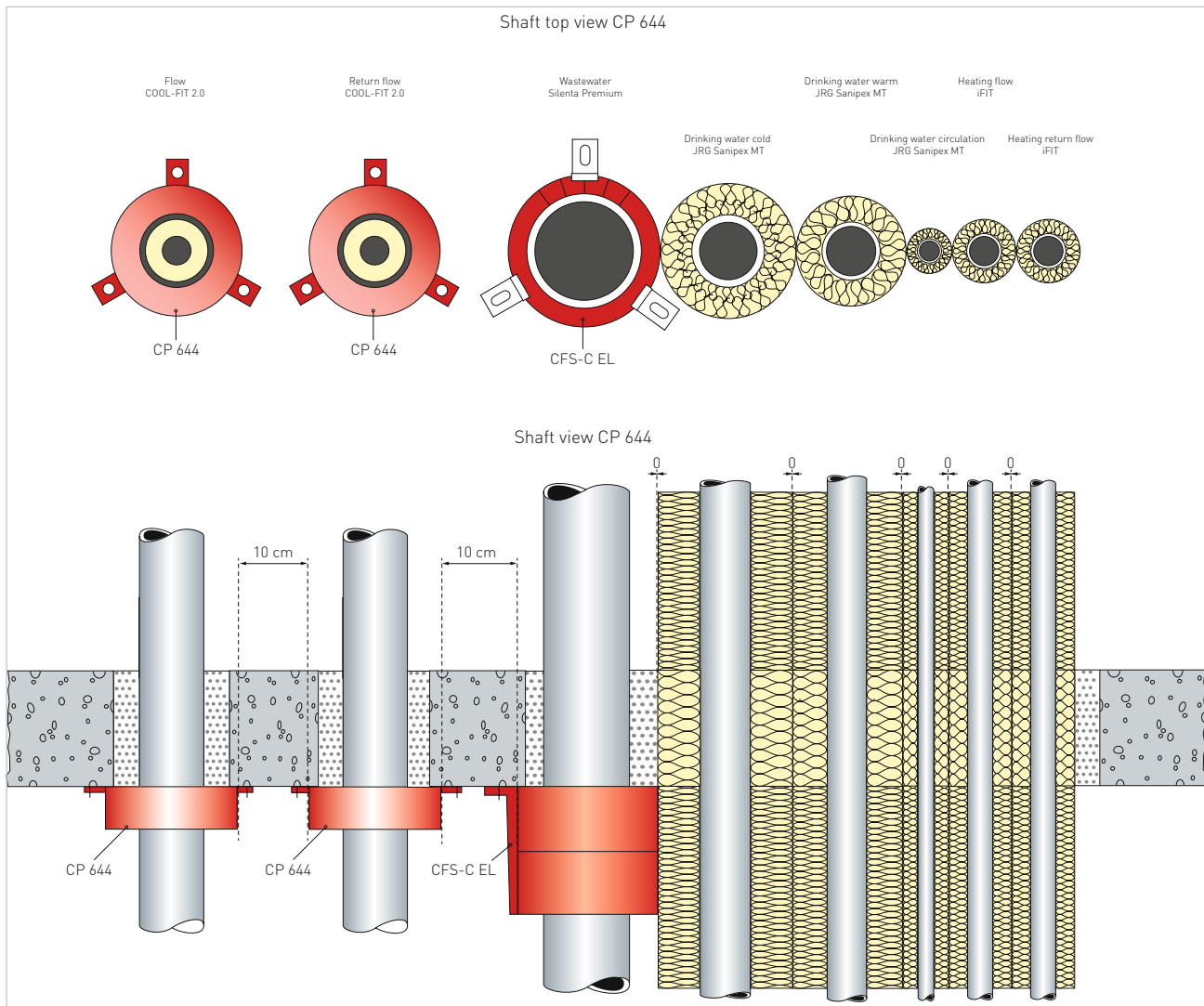

Additional tested fire-retarding sealing

The following firestop collars were tested with COOL-FIT 2.0/2.0F pipes.

Fire-retarding sealing	Manufacturer	Approval
ROKU® AWM II	Rolf Kuhn GmbH	ETA 17/0753
BIS Pacifyre® AWM II	Walraven	ETA 17/0753

The firestop system ROKU® R – type AWM II carries the European technical approval ETA 17/0753. COOL-FIT 2.0/2.0F was tested with AWM II firestop collars.

For detailed product information on AWM II see www.svt-global.com.

ROKU® System AWM II

System description

The ROKU® system AWM II consists of a firestop collar housing, which is equipped on the inside with several layers of the highly effective intumescent material "ROKU® Strip." In case of fire, the foaming material reacts with a strong foaming pressure and permanently seals the construction component opening against fire and smoke. On walls, one collar should be fitted on each side, and on ceilings only one collar underneath the ceiling.

Application areas

- Sealing of plastic pipes up to Ø 400 mm in solid walls, light partition walls, and solid ceilings
- For plastic pipes, mineral fiber-reinforced plastics, plastic composite pipes
- Suitable for insulated and non-insulated plastic pipes and acoustically insulating sewage pipes

Solutions for emergency corridors

Within emergency corridors the use of only non-combustible materials is allowed. The supplier Rockwool offers with Rockwool 800 a protection sleeve, made of mineral wool, which allows the use of normal combustible pipe within emergency areas. This solution is approved on pipe outer diameters of up to 160 mm.

For detailed information about Rockwool 800 see:

www.rockwool.de



Roxtec RS PPS seal

System description

The Roxtec RS PPS is a sealing for pipes through steel decks and bulkheads in vessels. The intumescent-based sealing strips that wrap around the plastic pipe ensure blocking of smoke, flames and water in case of fire.

Fire-retarding sealing	Manufacturer	Approval
Roxtec RS PPS und RS PPS/S	Roxtec International AB	MEDB000036A LR2090258SF

For detailed information about Roxtec see www.roxtec.com

1.4.5 Hydraulic design

Determination of pipe diameter based on flow rate (l/s)

As a first approximation, the required pipe cross-section for a certain flow rate can be calculated using the following formula

$$d_i = 18.8 \cdot \sqrt{\frac{Q_1}{v}} \quad \text{or} \quad d_i = 35.7 \cdot \sqrt{\frac{Q_2}{v}}$$

v flow velocity (m/s)
 d_i Pipe internal diameter (mm)
 Q₁ Flow rate (m³/h)
 Q₂ Flow rate (l/s)
 18.8 Conversion factor for units Q₁ (m³/h)
 35.7 Conversion factor for units Q₂ (l/s)

√ Example calculation of an internal diameter d_i

COOL-FIT 2.0 pipe	SDR11
Flow rate Q ₂	8 l/s
Usual flow velocity v	1.5 m/s

$$d_i = 35.7 \cdot \sqrt{\frac{8}{1.5}} = 82.4 \text{ mm}$$

A pipe with d90/d140 is used. After the internal diameter has been determined that way, the actual flow rate is determined with the following formula:

$$v = 354 \cdot \frac{Q_1}{d_i^2} = 1.9 \frac{\text{m}}{\text{s}} \quad \text{or} \quad v = 1275 \cdot \frac{Q_2}{d_i^2} = 1.9 \frac{\text{m}}{\text{s}}$$

v Flow velocity v (m/s)
 d_i Pipe internal diameter (mm)
 Q₁ Flow rate (m³/h)
 Q₂ Flow rate (l/s)
 354 Conversion factor for units Q₁ (m³/h)
 1275 Conversion factor for units Q₂ (l/s)

Determination of pipe diameter based on cooling capacity (kW)

As a first approximation, the required pipe cross section for a certain cooling capacity can be calculated using the following formula.

$$d_i = 18.8 \cdot \sqrt{\frac{Q_L \cdot 3600}{\Delta T \cdot c \cdot \rho \cdot v}}$$

d_i Pipe inner diameter (mm)
 Q_L Cooling capacity in kW
 ΔT Temperature difference supply - return (K)
 c Specific heat capacity (kW*s/(kg*K))
 ρ Density of the medium (kg/m³)
 v Flow velocity (m/s)

√ Example for calculating the inner diameter d_i based on cooling capacity with water medium water

Cooling capacity Q_L	200 kW
Specific heat capacity (20 °C) c	4.187 kJ/(kg*K)
Water density (20 °C) ρ	998.2 kg/m ³
Temperature difference ΔT	10 K
Flow velocity v	1.5 m/s

$$d_i = 18.8 \cdot \sqrt{\frac{\left(\frac{200 \cdot 3600}{10 \cdot 4.187 \cdot 998.2}\right)}{1.5}} = 18.8 \cdot \sqrt{\frac{17.227}{1.5}} = 63.71 \text{ mm}$$

The flow rate should be estimated on the basis of the intended purpose of the pipe. As a guide for the flow rate, the following specifications apply.

Liquids

$v = 0.5 - 1.0$ m/s for the suction side

$v = 1.0 - 3.0$ m/s for the pressure side

Gases

$v = 10 - 30$ m/s

This method of calculation of pipe diameter does not allow for hydraulic losses. They must be calculated separately. The following sections serve that purpose.

(m ³ /h)	(l/min)	(l/s)	(m ³ /s)
1.0	16.67	0.278	2.78×10^{-4}
0.06	1.0	0.017	1.67×10^{-5}
3.6	60	1.0	1.00×10^{-3}
3'600	60'000	1'000	1.0

Conversion table with units of flow rate.

Correlation of outer diameter - inner diameter

To determine the outer diameter based on the internal diameter and SDR, the following formula can be used:

$$d = d_i \cdot \frac{SDR}{SDR - 2}$$

Correlation between pipe external and internal diameter

d_i (mm)	16	20	26	33	41	52	61	74	90	102	115
d (mm)	20	25	32	40	50	63	75	90	110	125	140

1.4.6 Nomogram for easy calculation of diameter and pressure loss

The nomogram below can be used to simplify the determination of the diameter required. The pressure loss in the pipe can be read off per meter of the pipe length.

⚠ The pressure loss calculated using the nomogram only applies to flows of substances with density 1000 kg/m³, i.e. water. Further pressure losses from fittings, valves, etc. also need to be considered using the instructions that follow.

Using the nomogram

Based on a flow velocity of 1.5 m/s, a line is drawn through the desired flow rate (i.e. 30 m³/h) to the axis which shows an internal diameter d_i (\approx 84 mm). Here, a closely matching diameter (74 mm for SDR11) and a second line is drawn back through the desired flow rate to the pressure drop axis Δp (5 mbar per meter of pipe).

Nomogram for COOL-FIT 2.0 pipe (PE100, SDR11) using the metric system.

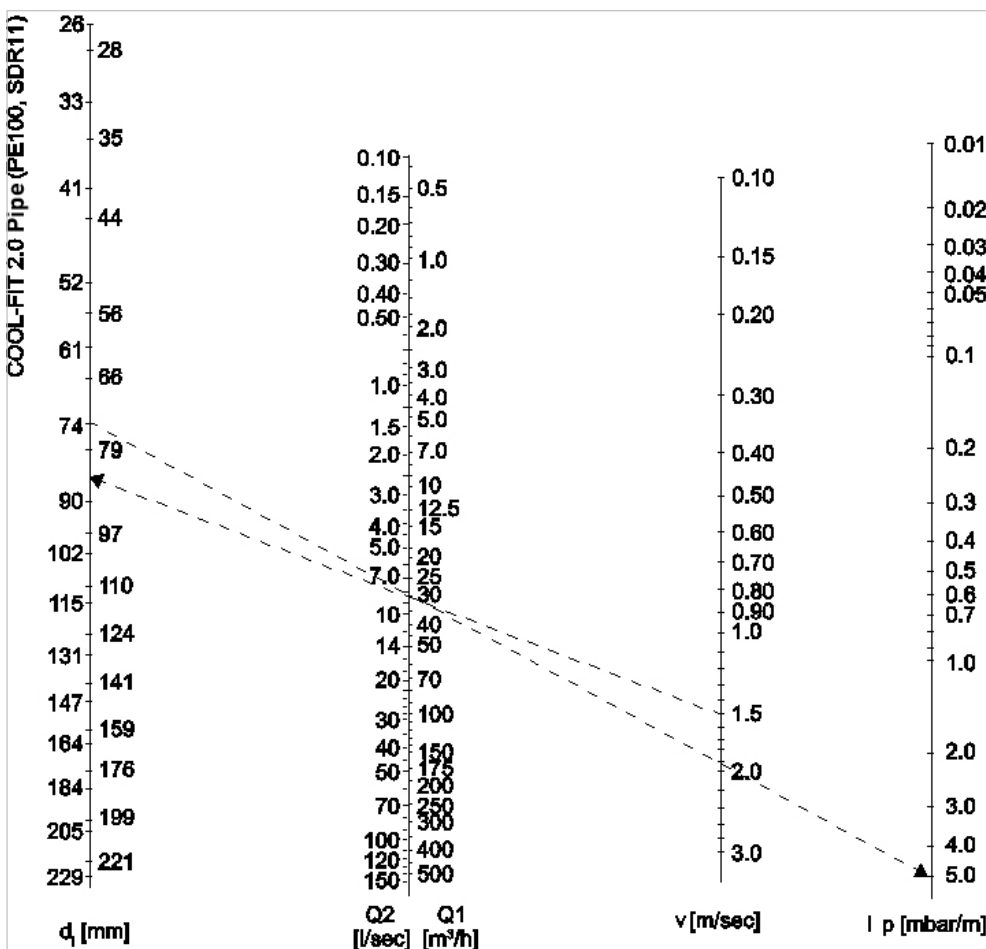

i For detailed information on the determination of diameter and pressure loss, see Planning Fundamentals "Hydraulic calculation and pressure losses of metric industrial piping systems".

1.4.7 Dimension comparison COOL-FIT 2.0 / 2.0F / 2.0 Push System vs. metal

COOL-FIT 2.0 / 2.0F			Stainless steel pipe		Copper pipe
d (mm)	d _i (mm)	DN	Inch	da (mm)	da (mm)
32	26.3	25	1	33.4	28
40	32.6	32	1¼	42.2	35
50	40.8	40	1½	48.3	42
63	51.4	50	2	60.3	54
75	61.4	65	2½	73.0	76.1
90	73.6	80	3	88.9	88.9
110	90.0	100	4	114.3	108
140	114.6	125	5	141.3	

d Nominal external diameter of PE pipe
 d_i Nominal internal diameter of pipe

COOL-FIT Push System			Stainless steel pipe		Copper pipe
d (mm)	d _i (mm)	DN	Inch	da (mm)	da (mm)
16	12	12	¾	17.1	15
20	16	15	½	21.3	18
25	20	20	¾	26.7	22
32	26	25	1	33.4	28

d Nominal external diameter of pipe
 d_i Nominal internal diameter of pipe

1.4.8 Pressure loss

Pressure loss in straight pipe

In determining pressure losses in straight pipe sections, a distinction is made between laminar and turbulent flows. The Reynolds number (Re) determines this. The change from laminar to turbulent occurs at the critical Reynolds number $Re_{crit} = 2320$.

In practice laminar flows occur particularly for the movement of viscous liquids such as lubricating oils. In most applications, thus including flows of aqueous materials, there is turbulent flow with a substantially more uniform velocity distribution over the pipe cross-section than in laminar flow.

The pressure loss in a straight pipe section is inversely proportional to the pipe diameter and is calculated as follows:

$$\Delta p_R = \lambda \cdot \frac{L}{d_i} \cdot \frac{\rho}{2 \cdot 10^2} \cdot v^2$$

- Δp_R Pressure loss in the straight pipe run (bar)
- λ Pipe friction factor = 0.02
- L Length of the straight pipe section (m)
- d_i Inner diameter of the pipe (mm)
- ρ Density of the flow material (kg/m³) for water 20°C = 998.2 kg/m³
- v Flow velocity v (m/s)

 In practice, when making a rough calculation (i.e. smooth plastic pipe and turbulent flow) it is enough to use the value $\lambda = 0.02$ to represent the hydraulic pressure loss.

Pressure losses of fittings

Coefficient of resistance

The pressure losses depend upon the type of fitting as well as on the flow in the fitting. The so-called coefficient of resistance (ζ -value) is used for calculations.

Calculation of the pressure loss

To calculate the total pressure loss in all fittings in a piping system, take the sum of the individual losses, i. e. the sum of all the ζ -values. The pressure loss can then be calculated according to the following formula:

$$\Delta p_{Fi} = \sum \zeta \cdot \frac{v^2}{2 \cdot 10^5} \cdot \rho$$

Δp_{Fi} Pressure loss of all fittings (bar)
 $\sum \zeta$ Sum of all individual losses
 v Flow velocity v (m/s)
 ρ Density of the medium (kg/m³)

Ceta-values fittings COOL-FIT 2.0

Designation	Symbol	Coefficient of resistance ζ
Couplers		0.1
Elbow 90°		1.2
Elbow 45°		0.3
Tee ¹⁾		1.3
Reducer (contraction)		0.5
Reducer (enlargement)		1.0
Flange joint, transition fitting	d32: 0.8 d40: 0.7 d50: 0.6	d63: 0.4 d75: 0.3 d90-d225: 0.1
Flexible hoses	1/2": 2.0 3/4": 1.8 1": 1.4	1 1/4": 1.1 1 1/2": 1.0 2": 0.8
Weld-in port with female thread		0.2
Weld-in port PE spigot		0.1
		0.9
		1.4

¹⁾ For a more detailed view, differentiate between coalescence and separation. Ceta values up to a maximum of 1.3 can be found in the respective literature.

Designation	Symbol	Coefficient of resistance ζ
Weld-in port PE/iFIT		0.1
		1.1
		3.3
Weld-in port PE/ Sanipex MT		0.1
		1
		1.3

Ceta-values fittings COOL-FIT 2.0 Push System

Designation	Symbol	Dimension	Coefficient of resistance ζ
Couplers		d16	3.7
		d20	4.7
		d25	2.8
		d32	6.7
90° angle		d16	6.3
		d20	8.7
		d25	5.2
		d32	11.0
Pipe bend 90°, bent manually		d16	0.1
		d20	0.1
		d25	0.1
		d32	0.1
Pipe bend 45°, bent manually		d16	0.1
		d20	0.1
		d25	0.1
		d32	0.1
Tee Main		d16	3.8
		d20	4.8
		d25	2.8
		d32	6.4
Tee Branch		d16	6.4
		d20	9.5
		d25	5.5
		d32	12.4
Tee, reduced Main		d20-d16	3.1
		d25-d16	2.5
		d25-d20	3.4
		d32-d16	2.5
		d32-d20	3.4
		d32-d25	2.6

Designation	Symbol	Dimension	Coefficient of resistance ζ
Tee, reduced Branch		d20-d16	4.6
		d25-d16	3.1
		d25-d20	5.0
		d32-d16	3.2
		d32-d20	4.7
		d32-d25	4.9
Reducer		d20-d16	3.1
		d25-d16	2.5
		d25-d20	3.4
		d32-d16	2.5
		d32-d20	3.3
		d32-d25	2.7

Pressure losses in valves

The k_v factor is a convenient means of calculating the hydraulic flow rates for valves. It allows for all internal resistances and for practical purposes is regarded as reliable. It is defined as the flow rate of water in liters per minute with a pressure drop of 1 bar across the valve. The technical data of the Georg Fischer Piping Systems valves contains the k_v values as well as pressure loss charts. The latter make it possible to read off the pressure loss directly. But the pressure loss can also be calculated from the k_v value according to the following formula:

$$\Delta p_{Ar} = \left(\frac{Q}{k_v} \right)^2 \cdot \frac{\rho}{1000}$$

Δp_{Ar} Pressure loss for the valve (bar)
 Q Flow rate (m³/h)
 ρ Density of the conveyed medium (kg/m³) (1 g/cc = 1000 kg/m³)
 k_v Valve characteristic value (m³/h)

k_v 100-values COOL-FIT 2.0

DN (mm)	Inch (")	d (mm)	k_v 100 (l/min)	Cv 100 (gal/min)	k_v 100 (m ³ /h)
25 ¹	1	32	700	49.0	42
32 ¹	1 ¼	40	1'000	70.0	60
40 ¹	1 ½	50	1'600	112.0	96
50 ¹	2	63	3'100	217.1	186
65 ¹	2 ½	75	5'000	350.0	300
80 ¹	3	90	7'000	490.0	420
100 ²	4	110	3'800	455	390
125 ²	5	140	8'600	602	516

- ¹ COOL-FIT 2.0 Ball valve
- ² COOL-FIT 2.0 Butterfly valve

Flow characteristic Ball valve

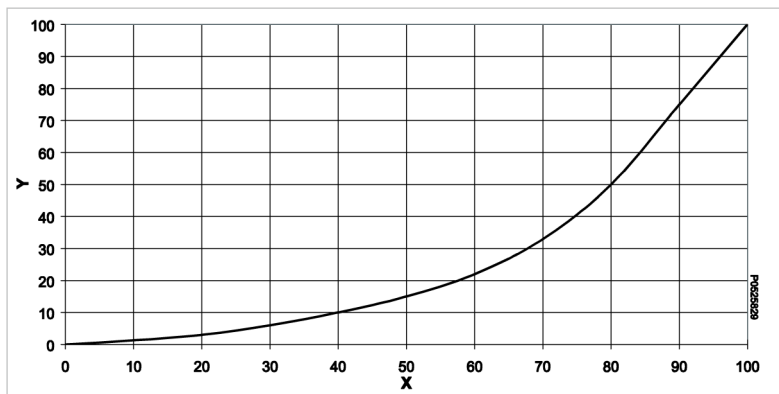

- X Opening angle (%)
- Y k_v , Cv value (%)

Flow characteristic butterfly valve

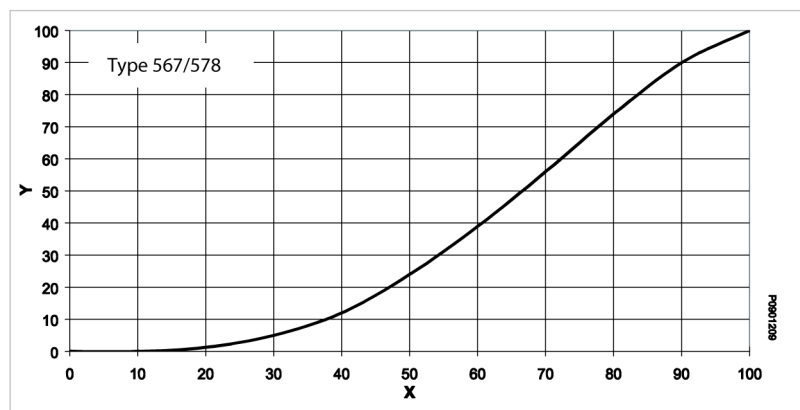

X Opening angle (%)
 Y k_v , C_v value (%)

k_v 100-values Ball valve COOL-FIT 2.0 Push System

DN (mm)	Inch (")	d (mm)	k_v 100 (l/min)	C_v 100 (gal/min)	k_v 100 (m ³ /h)
12	3/8	16	16.3	4.3	1.0
15	1/2	20	16.3	4.3	1.0
20	3/4	25	29.5	7.8	1.8
25	1	32	29.5	7.8	1.8

k_v 100-values Flow control valve COOL-FIT 2.0 Push System

DN (mm)	Inch (")	d (mm)	k_v 100 (l/min)	C_v 100 (gal/min)	k_v 100 (m ³ /h)
12	3/8	16	30.8	8.2	1.85
15	1/2	20	30.8	8.2	1.85
20	3/4	25	83.3	22.0	5.0
25	1	32	83.3	22.0	5.0

⚠ The use of antifreeze agents changes the viscosity and density of the medium. Depending on the proportion added, the actual flow rate therefore deviates from the displayed flow rate. Please contact GF Piping Systems for further information.

Pressure difference between the static pressure

If the piping system is installed vertically, then a geodetic pressure difference must be calculated for it. This pressure difference is calculated as follows:

$$\Delta p_{\text{geod}} = \Delta H_{\text{geod}} \cdot \rho \cdot 10^{-4}$$

Δp_{geod} Geodetic pressure difference (bar)

ΔH_{geod} Difference in elevation of the piping system (m)

ρ Density of the medium (kg/m³) (1 g/cm³ = 1000 kg/m³)



At closed systems, the geodetic pressure difference does not need to be considered. This is typically the case for cooling systems.

Sum of pressure losses

The sum of all pressure drops for a piping system is calculated as follows:

$$\Sigma \Delta p = \Delta p_R + \Delta p_{Fi} + \Delta p_{Ar}$$



Example for pressure drop calculations

The following example illustrates the calculation process for determining the pressure loss of a piping system.

		Number of Fittings
COOL-FIT 2.0 pipe	d40 mm	12 x 90° angle
SDR11 – flow rate	1.5 l/s	4 x 45° angle
Medium	Wasser	3 x T-piece
Density of the medium	1.0 g/cm ³	3 x screws
Length straight pipe	15 m	2 x flange connections
Height difference	2.0 m	1 x ball valve, 80 % opened

The wall thickness of the piping system can be calculated as follows with the SDR:

$$e = \frac{d}{\text{SDR}} = \frac{40 \text{ mm}}{11} = 3.6 \text{ mm}$$

The inner diameter of the piping system is as follows:

$$d_i = d - 2 \cdot e = d - \frac{2 \cdot d}{\text{SDR}} = 32.8 \text{ mm}$$

With the desired flow rate of 1.5 l/s, the flow velocity is as follows:

$$v = 1275 \cdot \frac{Q_2}{d_i^2} = 1275 \cdot \frac{1.5}{32.8^2} \frac{\text{m}}{\text{sec}} = 1.78 \frac{\text{m}}{\text{sec}}$$

Pressure loss	Formula
Pressure loss for straight pipe sections	$\Delta p_R = 0.02 \cdot \frac{15}{32.8} \cdot \frac{1000}{2 \cdot 10^2} \cdot 1.78^2 = 0.14 \text{ bar}$
Pressure loss for fittings incl. connections	$\Sigma \zeta = (12 \cdot 1.2) + (4 \cdot 0.3) + (3 \cdot 1.3) + (5 \cdot 0.7) = 23$ $\Delta p_{Fi} = 23 \cdot \frac{1.78^2}{2 \cdot 10^5} \cdot 1000 = 0.36 \text{ bar}$
Pressure loss for the valve 80 % opened. With the flow characteristics diagram for ball valves type 546, from an 80% open angle a percentile kv value of 50 % can be read out, that means 50 % of the kv value 100: 0.5 * 60 m³/h (flow rate 1.5 l/s = 5.4 m³/h)	$\Delta p_{Ar} = \left(\frac{5.4}{0.5 \cdot 60}\right)^2 \cdot \frac{1000}{1000} = 0.03 \text{ bar}$
Whole pressure loss of the piping	$\Sigma \Delta p = 0.14 \text{ bar} + 0.36 \text{ bar} + 0.03 \text{ bar} = 0.53 \text{ bar}$

Formulas for calculating pressure losses

1.4.9 Z-dimension method

Overview

The pressure of competition and high costs on site makes it essential to install piping system systems efficiently. The GF Piping

Systems method of assembly is highly suited to this task. It replaces the tedious and time-consuming cutting to size of one pipe at a time by a fast and precise way of preparing whole groups of pipe according to plans or jigs.

The respective pipe group with the corresponding design dimensions and cut lengths can be entered in the isometric paper of GF Piping Systems.

Please adhere to the following guidelines for drawing:

Pipe running perpendicular to one another	Pipe running diagonally
---	-------------------------

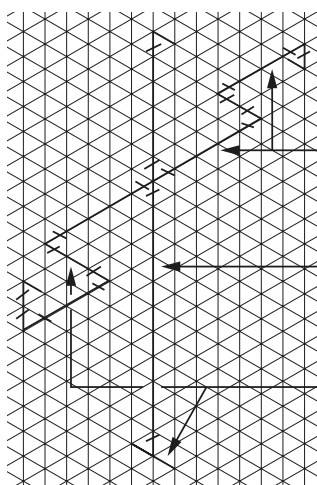

Horizontally:
left and right

Vertical

Horizontally:
front and rear

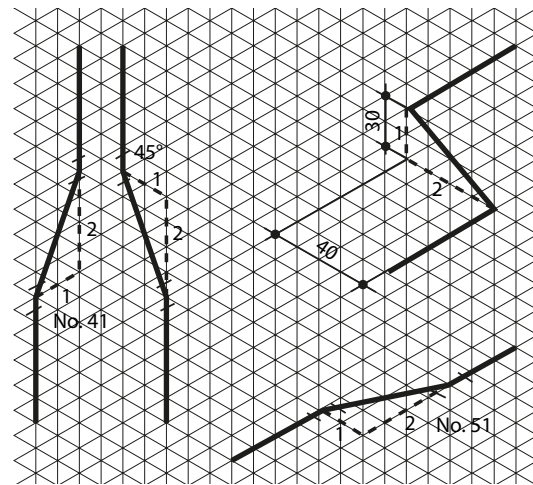

The z-dimensions of the fittings are needed for determining the actual cutting lengths of the pipe. The tables in our product ranges and in the online catalogues contain all the relevant data for the fittings. The length of pipe to be cut is given as in the following diagram by the distance between the center of adjoining fittings less the sum of the z-dimension of the fittings.

Procedure

Electrofusion

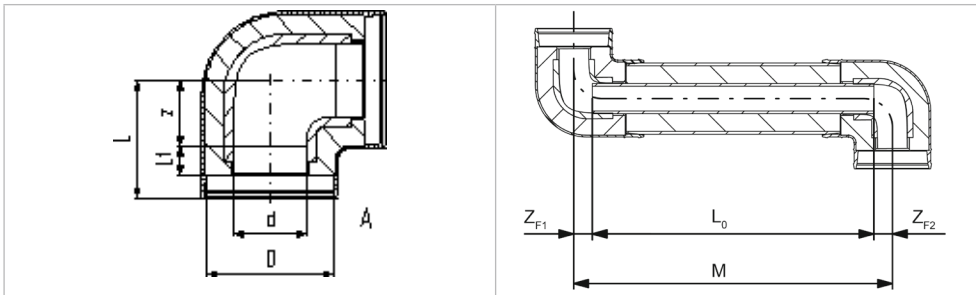

L laid pipe length

Formula for determining the required pipe length

$$L_0 = M - Z_{F1} - Z_{F2}$$

L_0 Pipe length to be cut

M Center to center distance between fittings

Z_{F1} z-measurement for fitting 1

Z_{F2} z-measurement for fitting 2

√ Example

Dimension	d32/D75
Center to center distance M	1'000 mm
z measurement for 90° elbow Z_{F1}	20 mm
z measurement for 90° elbow Z_{F2}	20 mm
M = 1000 mm; $L_0 = ?$	
$L_0 = 1000 \text{ mm} - 20 \text{ mm} - 20 \text{ mm} = 960 \text{ mm}$	

1.4.10 Length changes and flexible sections

Overview

Length changes ΔL and expansion bend L_B - General

Thermoplastics are subject to higher thermal expansion and contraction than metallic materials. Pipe installed above ground, against walls or in ducts, require changes in length to be taken up in order to prevent any superimposed extra strain on the pipe. This applies especially to pipe exposed to operating temperature variations.

To accommodate a change in length, the following options can be considered:

- A Flexible sections
- B Flexible hoses
- C Compensators

Flexible sections are the most common, the simplest and the most economical solution. The calculations for and the positioning of flexible sections are therefore described in detail.

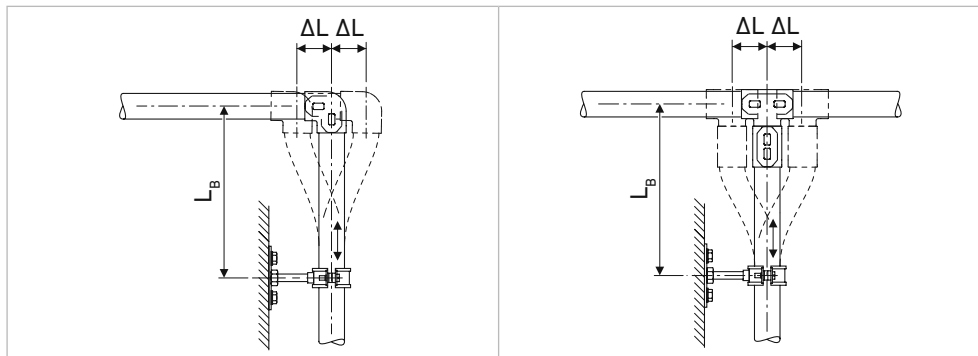

ΔL Change in length
 L_B Flexible section

Fundamentals

The low elasticity of thermoplastics allows changes in length to be taken up by special pipe sections, where pipe supports are positioned so that they can take advantage of the natural flexibility of the material. The length of such sections is determined by the diameter of the piping system and the extent of the thermal expansion to be compensated.

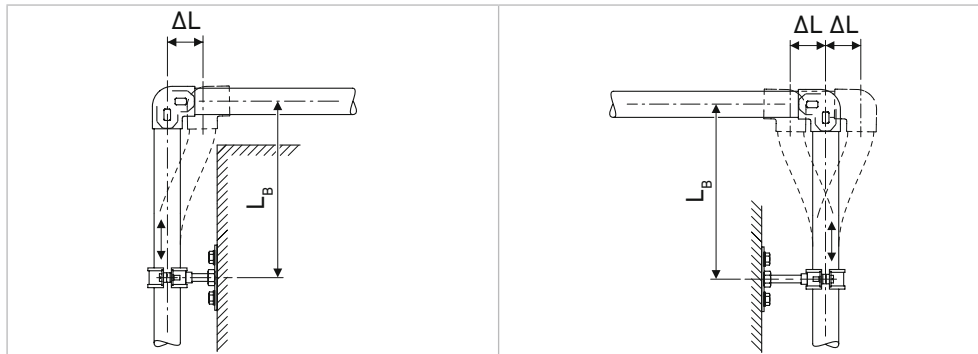

Flexible sections arise naturally at any branching or change in direction of the piping system. The movement L_B of the flexible section as a result of a change ΔL in the length must not be restrained by fixed pipe brackets, wall protrusions, girders or the like.

Calculation of length changes and flexible sections COOL-FIT 2.0 / 2.0F

To determine the change in length due to temperature ΔL (mm) of COOL-FIT 2.0 / 2.0F pipe, the following temperatures must be known:

- installation temperature
- minimum flow temperature
- maximum flow temperature
- minimum ambient temperature
- maximum ambient temperature

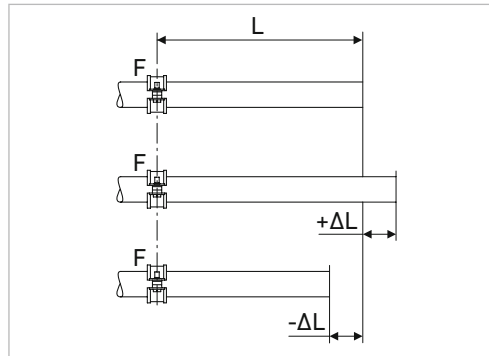

F Fixpoint
L Length of pipe section

■ The following tables show changes in length at different media temperatures for certain conditions. To determine the change in length for other conditions, the Cooling Calculation Tool can be used. Contact your GF Piping Systems representative or visit www.gfps.com



Example of use:

Installation temperature	25 °C
Max. flow temperature	25 °C
Min. flow temperature	See table
Max. ambient temperature	25 °C
Min. ambient temperature	25 °C

COOL-FIT 2.0

Length change ΔL (mm) at 20° C flow temperature					Length change ΔL (mm) at 15° C flow temperature				
L (m)	25	50	100	150	L (m)	25	50	100	150
d32	-5	-10	-21	-31	d32	-11	-21	-42	-63
d40	-6	-12	-24	-36	d40	-12	-25	-49	-74
d50	-8	-16	-32	-48	d50	-16	-32	-65	-97
d63	-8	-17	-34	-51	d63	-17	-35	-69	-104
d75	-9	-18	-36	-54	d75	-18	-36	-73	-109
d90	-10	-20	-40	-59	d90	-20	-40	-80	-120
d110	-11	-22	-44	-66	d110	-22	-45	-90	-134
d140	-11	-23	-45	-68	d140	-23	-46	-91	-137

L laid pipe length

Length change ΔL (mm) at 10° C flow temperature					Length change ΔL (mm) at 5° C flow temperature				
L (m)	25	50	100	150	L (m)	25	50	100	150
d32	-16	-32	-65	-97	d32	-22	-44	-88	-132
d40	-19	-38	-75	-113	d40	-26	-51	-102	-154
d50	-25	-49	-99	-148	d50	-33	-67	-133	-200
d63	-26	-53	-105	-158	d63	-36	-71	-142	-213
d75	-28	-55	-111	-166	d75	-37	-75	-149	-224
d90	-30	-61	-122	-183	d90	-41	-82	-164	-246
d110	-34	-68	-136	-203	d110	-46	-91	-182	-273
d140	-34	-69	-138	-207	d140	-46	-93	-185	-278

L laid pipe length

COOL-FIT 2.0F

Length change ΔL (mm) at 20° C flow temperature					Length change ΔL (mm) at 15° C flow temperature				
L (m)	25	50	100	150	L (m)	25	50	100	150
d32	-3	-6	-12	-17	d32	-6	-12	-24	-36
d40	-4	-7	-14	-21	d40	-7	-15	-29	-44
d50	-5	-10	-20	-29	d50	-10	-20	-40	-60
d63	-6	-12	-23	-35	d63	-12	-24	-47	-71
d75	-7	-13	-26	-39	d75	-13	-27	-54	-80
d90	-6	-13	-25	-38	d90	-13	-26	-52	-78
d110	-7	-15	-30	-45	d110	-15	-31	-61	-92
d140	-9	-17	-34	-51	d140	-17	-35	-70	-104

L laid pipe length

Length change ΔL (mm) at 10° C flow temperature					Length change ΔL (mm) at 5° C flow temperature				
L (m)	25	50	100	150	L (m)	25	50	100	150
d32	-9	-18	-37	-55	d32	-13	-25	-51	-76
d40	-11	-23	-45	-68	d40	-15	-31	-62	-92
d50	-15	-31	-62	-93	d50	-21	-42	-84	-126
d63	-18	-36	-73	-109	d63	-25	-49	-99	-148
d75	-20	-41	-82	-123	d75	-28	-56	-111	-167
d90	-20	-40	-80	-120	d90	-27	-54	-109	-163
d110	-23	-47	-93	-140	d110	-32	-63	-127	-190
d140	-26	-53	-106	-159	d140	-36	-72	-143	-215

L laid pipe length

Flexible section for COOL-FIT 2.0

The values for L_B (cm) from this table can be used for a given ΔL (mm) and the relevant pipe size:

Flexible section L_B (cm)													
ΔL (mm)	10	20	30	40	50	60	70	80	90	100	150	200	300
d32/75	71	101	123	142	159	174	188	201	214	225	276	318	390
d40/90	78	110	135	156	174	191	206	221	234	247	302	349	427
d50/90	78	110	135	156	174	191	206	221	234	247	302	349	427
d63/110	86	122	149	172	193	211	228	244	259	273	334	386	472
d75/125	92	130	159	184	206	225	243	260	276	291	356	411	503
d90/140	97	138	168	195	218	238	257	275	292	308	377	435	533
d110/160	104	147	180	208	233	255	275	294	312	329	403	465	570
d140/200	116	164	201	233	260	285	308	329	349	368	450	520	637

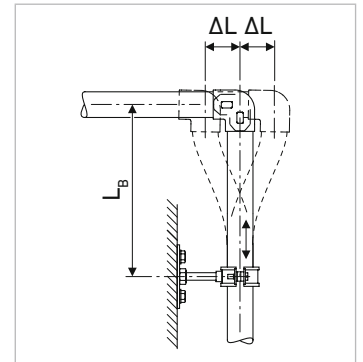

Flexible section for COOL-FIT 2.0F

The values for L_B (cm) from this table can be used for a given ΔL (mm) and the relevant pipe size:

Flexible section L_B (cm)													
ΔL (mm)	10	20	30	40	50	60	70	80	90	100	150	200	300
d32/75	92	130	159	183	205	225	243	259	275	290	355	410	503
d40/90	101	142	174	201	225	246	266	284	302	318	389	449	550
d50/90	101	142	174	201	225	246	266	284	302	318	389	449	550
d63/110	111	157	192	222	248	272	294	314	333	351	430	497	609
d75/125	118	168	205	237	265	290	313	335	355	375	459	530	649
d90/140	125	177	217	251	280	307	332	355	376	396	485	561	687
d110/160	134	190	232	268	300	328	355	379	402	424	519	599	734
d140/200	150	212	259	300	335	367	396	424	449	474	580	670	821

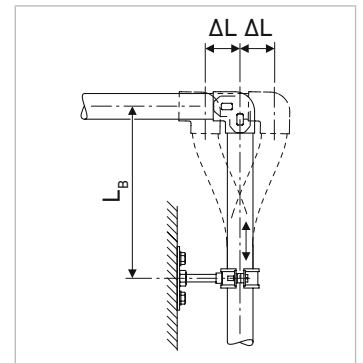

Calculation of length changes and flexible section COOL-FIT 2.0 Push System

As a first approximation, the change of the pipe length can be calculated using the following formula.

$$\Delta L = \alpha \cdot L \cdot \Delta T$$

ΔL	Length difference in mm
ΔT	Temperature difference in K
L	Length of pipeline in m
α	Linear coefficient of thermal expansion; 0.024 mm/(mK)

Change in length

Pipe length [m]	Temperature difference ΔT [K]					
	10	20	30	40	50	60
	Change in length [mm]					
1	0.2	0.5	0.7	1.0	1.2	1.4
2	0.5	1.0	1.4	1.9	2.4	2.9
3	0.7	1.4	2.2	2.9	3.6	4.3
4	1.0	1.9	2.9	3.8	4.8	5.8
5	1.2	2.4	3.6	4.8	6.0	7.2
6	1.4	2.9	4.3	5.8	7.2	8.6
7	1.7	3.4	5.0	6.7	8.4	10.1
8	1.9	3.8	5.8	7.7	9.6	11.5
9	2.2	4.3	6.5	8.6	10.8	13.0
10	2.4	4.8	7.2	9.6	12.0	14.4
20	4.8	9.6	14.4	19.2	24.0	28.8
30	7.2	14.4	21.6	28.8	36.0	43.2
40	9.6	19.2	28.8	38.4	48.0	57.6
50	12.0	24.0	36.0	48.0	60.0	72.0

Flexible section



Sample calculation

The length of the pipeline is 7 m. The thermally induced change in length of this pipe section must be absorbed by a flexible pipe leg. The difference between the installation temperature and the maximum operating temperature is 60 K.

Example: COOL-FIT 2.0 Push System

PE-RT pipe, dimension	d16
Material constant C	33
Change in length Δl	10.08 mm

Calculation of the length of the flexible pipe leg

$$L_B = C \cdot \sqrt{d \cdot \Delta l}$$

$$L_B = 33 \cdot \sqrt{(16 \text{ mm} \cdot 10.08 \text{ mm})}$$

$$L_B = 419.1 \text{ mm}$$

The length of the flexible pipe leg is derived from the pipe's change in length:

Graph reading example

PE-RT pipe, dimension	d16
Material constant C	33
Change in length Δl	10.08 mm

$L_B = 419.1 \text{ mm}$

Length of flexible pipe leg
a Change in length of the pipe
s Length of flexible pipe leg

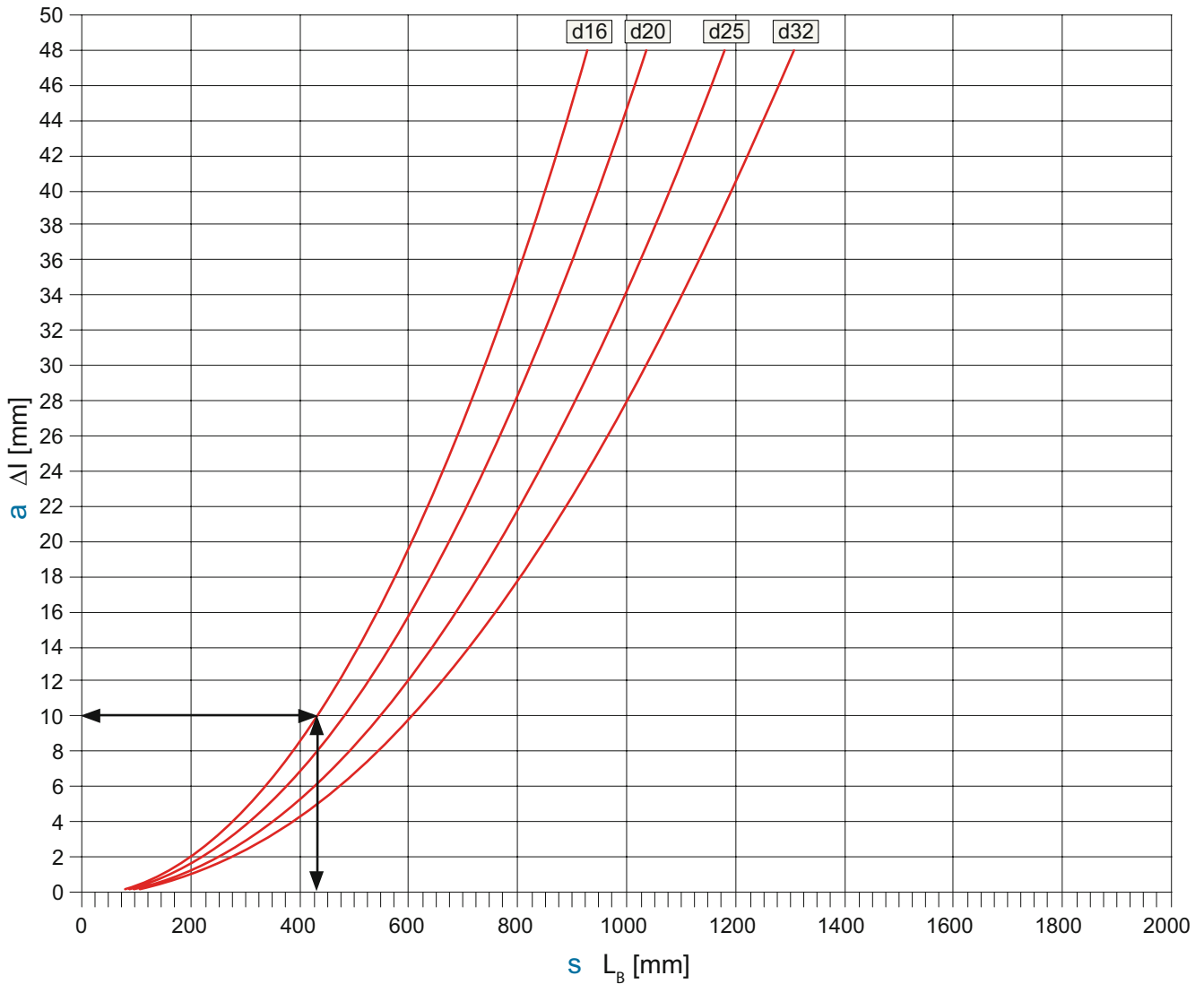

1.4.11 Handling expansion and contraction

Recommendations for installation

Length changes in pipe sections should always be accommodated through the arrangement of fixed brackets. The following examples show how the changes can be distributed in pipe sections by suitable positioning of fixed brackets:

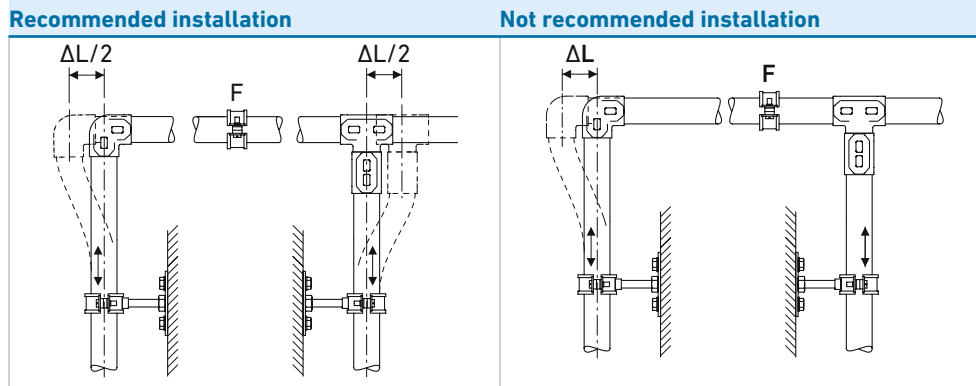

Expansion loops can be installed to take up changes in length when flexible sections cannot be included at a change in direction or branch in the piping system or if substantial changes in the length of a straight section need to be taken up. In such a case the compensation for changes in length is distributed over two flexible sections.

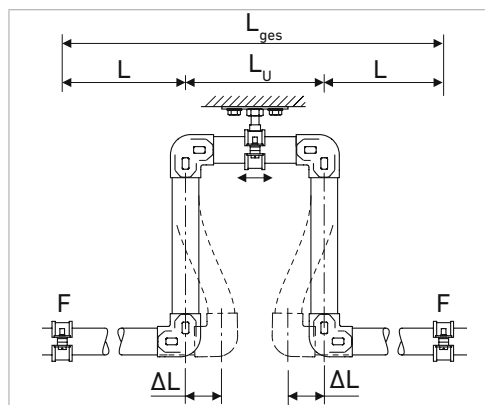

⚠ Bending stress can lead to leaks in mechanical joints.

Do not use any unions or flanged connections close to expansion bends and loops.

Pre-tensioning

In particularly difficult situations with large changes in one direction only, it is possible to pre-tensioning the flexible section during installation and thereby shorten its length L_B , as illustrated in the next example:



Example

Pipe length L	25 m
Diameter	d50/D90 mm
Installation temperature	25 °C
Min ambient temperature	25 °C konstant
Max ambient temperature	25 °C konstant
Min flow temperature	10 °C
Max flow temperature	25 °C

Change in length from the table or Cooling Calculation Tool:

$$-\Delta L = 29 \text{ mm}$$

A flexible section to take up a change in length of $\pm \Delta L = 29 \text{ mm}$ needs to be $L_B \text{ (mm)} = \sim 1350 \text{ mm}$ long according to the table.

If the flexible section is pre-tensioned to $\Delta L/2$, the flexible section required is reduced to $\sim 94 \text{ cm}$. The change in length starting from the 0 position is then $\pm \Delta L/2 = 29/2 = 14.5 \text{ mm}$.

By pre-tensioning the flexible section makes it possible to reduce its required length in installations where space is restricted. Pre-stressing also reduces the bending of the flexible section in service, improving the appearance of the piping system.

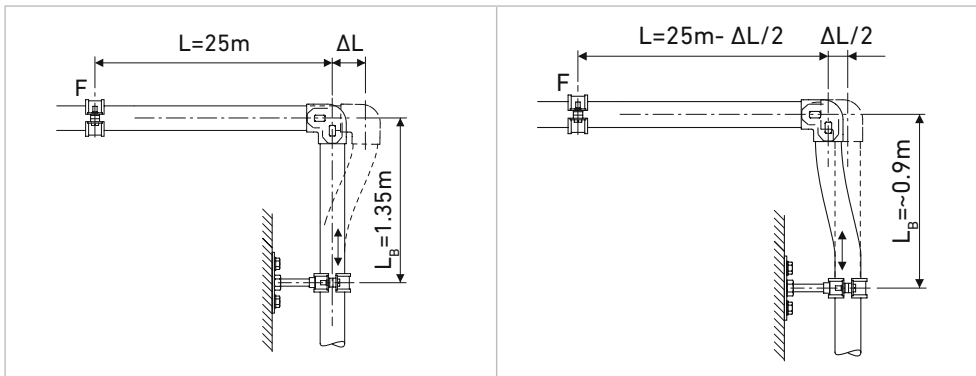

1.4.12 Pipe bracket spacing and support of piping systems

Overview

Installation of plastic pipe

COOL-FIT 2.0 pipe should be installed using supports designed for use with plastics and should then be installed taking care not to damage or overstress the pipe.

Thanks to the excellent insulating properties of the COOL-FIT 2.0 pipe and its hard, impact resistant outer jacket, standard pipe clamps may be used. Special insulation pipe clamps or cold clamps are not necessary.



Installation of COOL-FIT 2.0 Push System

COOL-FIT 2.0 Push System tubes must be installed using suitable tube supports. In doing so, the pipes must not be under too much tension.

The COOL-FIT 2.0 Push System, pipes can be inserted into standard sliding pipe clamps with the COOL-FIT 2.0 Push System, support carrier. Special insulation pipe clamps or cold clamps are not necessary.



A retaining clamp must be placed next to each fitting.



Arranging loose brackets

What is a loose bracket?

A loose bracket is a pipe bracket which allows axial movement of the pipe. This allows stress-free compensation of temperature changes and compensation of any other operating condition changes.

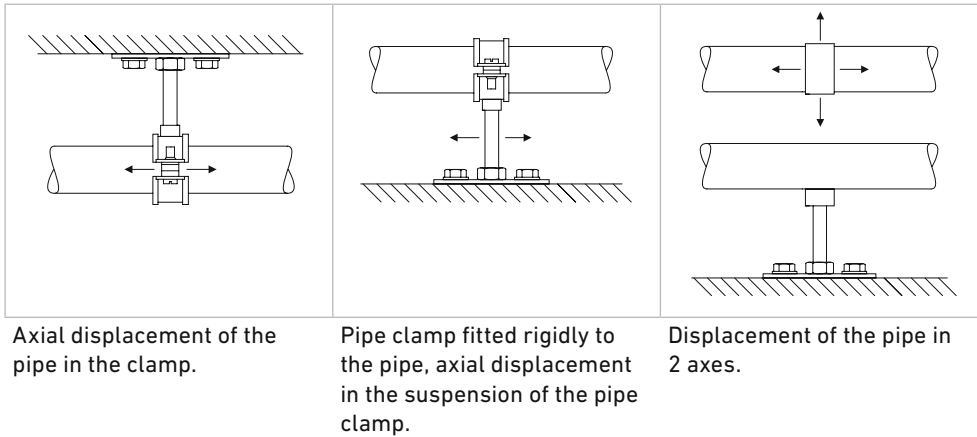

The inner diameter of the bracket must be larger than the outer diameter of the pipe to allow free movement of the pipe. The inner edges of the brackets should be free from any sharp contours to avoid damaging the pipe surface.

Another method is to use brackets with spacers in the bolts which also avoids clamping the bracket on the pipe

The axial movement of the piping may not be hindered by fittings arranged next to the pipe bracket or other diameter changes.

Sliding brackets and hanging brackets permit the pipe to move in different directions. Attaching a sliding block to the base of the pipe bracket permits free movement of the pipe along a flat supporting surface. Sliding and hanging brackets are needed in situations where the piping system changes direction and free movement of the pipe must be allowed.

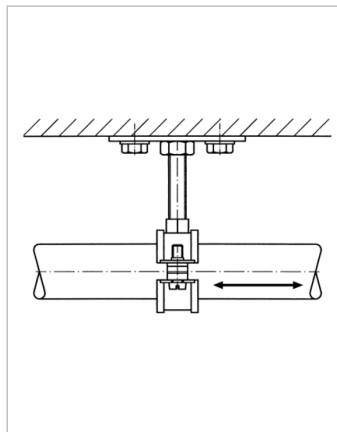

Spacers prevent pinching the pipe

Maximum pipe support distance

The maximum pipe support distances have been determined for conveying water on the basis of a specific deflection of the pipe between two clamps considered acceptable.

The maximum pipe support distance for COOL-FIT 2.0 pipes is always consistent independent of pressure and temperature.

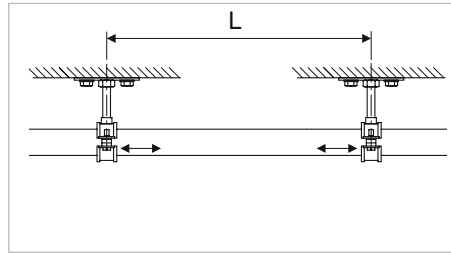

L Pipe clamp spacing

Maximum pipe support distance L for COOL-FIT 2.0

d/D (mm)	32/75	40/90	50/90	63/110	75/125	90/140	110/160	140/200
L (mm)	1'600	1'700	1'700	1'850	1'950	2'000	2'100	2'350

Maximum pipe support distance L for COOL-FIT 2.0F

d/D (mm)	32/75	40/90	50/90	63/110	75/125	90/140	110/160	140/200
L (mm)	2'200	2'300	2'300	2'400	2'500	2'600	2'700	2'900

Maximum pipe support distance L for COOL-FIT 2.0 Push System

d/D (mm)	16/44	20/48	25/54	32/61
L (mm)	1'200	1'200	1'700	2'200

The pipe clamp intervals from the table can be increased by 30% for vertical pipe. Multiply the values given by 1.3 in this case.

⚠ Pipe which are axially clamped and rigidly fixed must be tested for their resistance to kinking. In most cases, this test results in a reduction of the maximum internal pressure and more tightly spaced supports. The forces acting on the fixed points should be considered.

KLIP-IT pipe brackets

These robust plastic pipe brackets can be used not only under rigorous operating conditions, but also where the pipework is subject to aggressive media or atmospheric conditions. Pipe brackets and pipe clamps from GF Piping Systems are suitable for all pipe materials used.

Do not use KLIP-IT pipe brackets as fixed points!

⚠ From d90 upwards KLIP-IT pipe clamps must be mounted upright, as in the installation examples below.

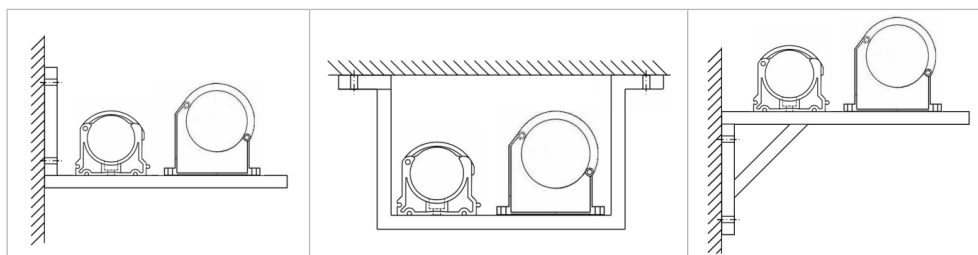

Arranging fixed points

A fixed point is a bracket which prevents the pipe from moving in any direction. The purpose of a fixed point is to control tension caused by temperature changes and guide elongation in a certain direction.

⚠ Fixed point design
 The pipe must not be fixed by clamping it in the pipe bracket. This can cause deformation and physical damage to the pipe, damage that sometimes does not appear until very much later.

⚠ Pipe brackets must be robust and mounted firmly to be able to take up the forces arising from changes in length in the piping system. Hanging brackets or KLIP-IT pipe brackets are unsuitable for use as fixed points.

COOL-FIT 2.0 fixed point

Fixed points for COOL-FIT 2.0 are established with the special COOL-FIT 2.0 fixed points. The product consists of fusion bands and pipe brackets. Electrofusion bands as permanent joints transmit the forces that occur in the pipe to the fixed point. The supplied pipe brackets serve to build up the fusion pressure during installation of the fusion bands and provide stability during operation. For fusion, use an MSA 2.x, MSA 4.x, MSA 250, 300, 350, 400 or commercially available 220-V electrofusion unit. If you use an MSA electrofusion unit by GF Piping Systems, use the y-cable kit with code No. 790 156 032. Please take note of the maximum allowed forces in the table below.

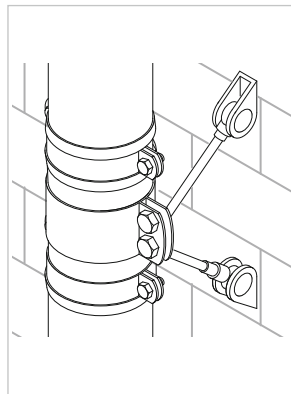

Diameter (mm)	d32/ D75	d40/ D90	d50/ D90	d63/ D110	d75/ D125	d90/ D140	d110 / D160	d140 / D200
Maximum force F (kN)	2.0	3.0	5.0	8.0	10.0	10.0	10.0	10.0

⚠ COOL-FIT 2.0 fixed points must be calculated on the basis of the application. Fixed point brackets and cross braces are not included.

Scope of delivery



- 1 Clamps to maintain fusion pressure
- 2 Electrofusion band

Y-cable kit for COOL-FIT fixed points

The COOL-FIT Y-cables can be used for a faster installation of COOL-FIT 2.0 fix points. Since electrofusion bands always come in pairs, Y-cables allow for a simultaneous fusion process, cutting fusion time in half.

COOL-FIT 2.0 fixed point for higher forces

For applications with higher forces, such as long risers, fixed points must be planned specifically for the application. Attachment to the beam is via a weld-on plate on the metal pipe clamp. The clamp is positioned between two COOL-FIT electrofusion fittings and is subsequently insulated. The insulation is designed for indoor applications, for outdoor applications further precautions are required to protect the insulation.

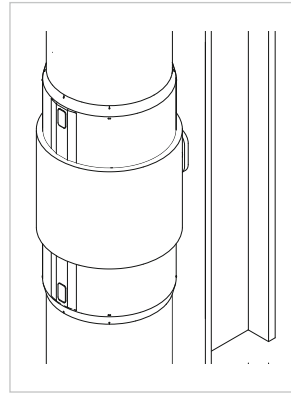

Diameter (mm)	d140 / D200
Maximum force F (kN)	35.0

⚠ COOL-FIT fixed points for higher forces must be calculated according to the application. The pipeline, support, weld seam type and other influencing factors must be taken into account in the force analysis. Please contact GF Advanced Engineering.

Example of maximal achievable riser length:

- Installation temperature -5 to +40°C
- Ambient temperature -5 to +45°C
- Flow temperature +6 to +47°C
- Fixpoint position Middle of the riser pipe
- Pressure on top level 3 bar (P_{Top})
- Support distance vertical Equal to horizontal
- Pipe class d32 - d140 SDR11

	Pipe support distance reduced for long riser		Fixpoint		Fixpoint for increased forces	
	Horizontal [m]	Vertical [m]	Max. riser length (L _{Riser}) [m]	Fixpoint force [kN]	Max. riser length (L _{Riser}) [m]	Fixpoint force [kN]
d32/75	1.6	1.6	32.5	0.6		
d40/90	1.7	1.7	40.5	1.0		
d50/90	1.7	1.7	32.5	1.0		
d63/110	1.9	1.9	39.5	1.9		
d75/125	2.0	2.0	43.5	2.9		
d90/140	2.0	2.0	48.0	4.4		
d110/160	2.1	2.1	52.0	6.6		
d140/200	2.4	2.4	48.5	10.0	54.5	11.2

⚠ Following sections are recommended to be proofed by GF Advanced Engineering before installation:

- Riser pipe with multiple dimensions
- Installation differ from normal installation with fixpoint in the middle

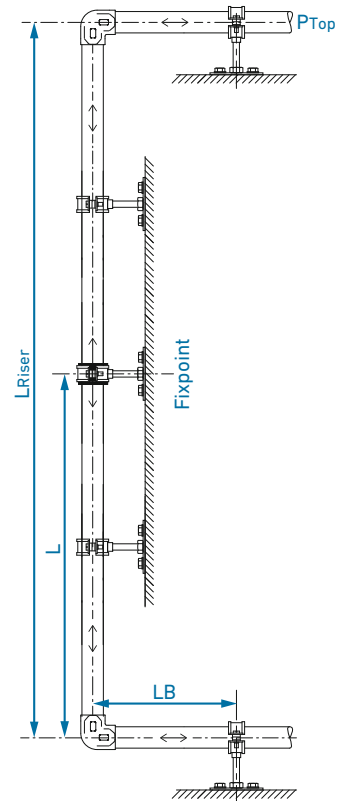

COOL-FIT 2.0F fixed points

Four half shells which are cemented on both sides to the fixed point pipe clamp.

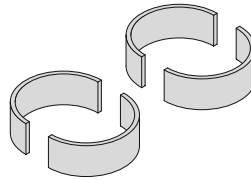

Diameter (mm)	d32/ D75	d40/ D90	d50/ D90	d63/ D110	d75/ D125	d90/ D140	d110 / D160	d140 / D200
Maximum force F (kN)	2.0	3.0	5.0	8.0	10.0	10.0	10.0	10.0

⚠ COOL-FIT 2.0F fixed points must be calculated on the basis of the application. Fixed point brackets and cross braces are not included.

Rigidly fixed installations

⚠ Pipe which are axially clamped and rigidly fixed must be tested for their resistance to kinking. In most cases, this test results in a reduction of the maximum internal pressure and more tightly spaced supports. The forces acting on the fixed points should be considered.

COOL-FIT 2.0 / 2.0F pipes and fittings are suitable for a rigidly fixed installation

Values for forces acting on fixed points as well as the resulting pipe bracket spacing are listed in following tables.

Example of use:

Installation temperature	25 °C
Min. ambient temperature	25 °C constant
Max. ambient temperature	25 °C constant
Min. flow temperature	See table
Max. flow temperature	25 °C

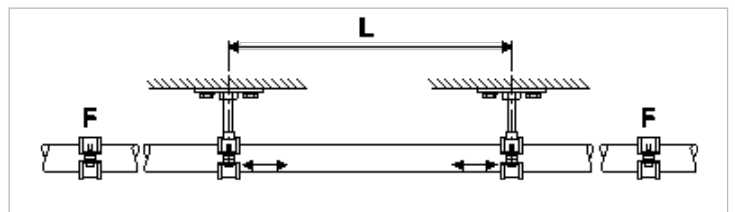

Fixed installation, maximum axial forces (kN) at 15°C fluid temperature

d/D (mm)	d32/75	d40/90	d50/90	d63/110	d75/125	d90/140	d110/160	d140/200
F (kN)	0.38	0.59	0.87	1.38	1.92	2.74	4.06	6.54
L (mm)	1'600	1'700	1'700	1'850	1'950	2'000	2'100	2'350

* max allowed force for COOL-FIT fixed point exceeded

Fixed installation, maximum axial forces (kN) at 10°C fluid temperature

d/D (mm)	d32/75	d40/90	d50/90	d63/110	d75/125	d90/140	d110/160	d140/200
F (kN)	0.58	0.92	1.36	2.15	2.99	4.28	6.33	10.21*
L (mm)	1'600	1'700	1'700	1'850	1'950	2'000	2'100	2'350

Fixed installation, maximum axial forces (kN) at 5°C fluid temperature

d/D (mm)	d32/75	d40/90	d50/90	d63/110	d75/125	d90/140	d110/160	d140/200
F (kN)	0.81	1.27	1.88	2.98	4.13	5.92	8.76	14.13*
L (mm)	1'600	1'700	1'700	1'850	1'950	2'000	2'100	2'350

COOL-FIT 2.0F

Fixed installation, maximum axial forces (kN) at 15°C fluid temperature								
d/D (mm)	d32/75	d40/90	d50/90	d63/110	d75/125	d90/140	d110/160	d140/200
F (kN)	0.38	0.60	0.88	1.39	1.93	2.75	4.07	6.56
L (mm)	2'200	2'300	2'300	2'400	2'500	2'600	2'700	2'900
Fixed installation, maximum axial forces (kN) at 10°C fluid temperature								
d/D (mm)	d32/75	d40/90	d50/90	d63/110	d75/125	d90/140	d110/160	d140/200
F (kN)	0.59	0.93	1.37	2.17	3.01	4.29	6.35	10.25*
L (mm)	2'200	2'300	2'300	2'400	2'500	2'600	2'700	2'900
Fixed installation, maximum axial forces (kN) at 5°C fluid temperature								
d/D (mm)	d32/75	d40/90	d50/90	d63/110	d75/125	d90/140	d110/160	d140/200
F (kN)	0.81	1.28	1.89	2.99	4.16	5.94	8.78	14.18*
L (mm)	2'200	2'300	2'300	2'400	2'500	2'600	2'700	2'900

⚠ Please contact GF Piping Systems for rigidly fixed installations that contain ball valves and mechanical joints as well as if the max. allowed force on the fixed points are exceeded

1.4.13 Bending of COOL-FIT 2.0 Push System pipes

Manual bending

COOL-FIT 2.0 Push System pipes can be bent by hand without the use of bending tools. Ensure the pipes do not kink when bending them.

Hydraulic cylinders or bending springs

Commercially available hydraulic cylinders can be used, considering the following aspects:

- The shape of the bending gauge must correspond with the outside diameter of the media pipe.
- Do not use internal bending springs.
- Ensure the bending radius is not less than $3.5 \cdot d$.

COOL-FIT 2.0 Push System pipes can be easily shaped into the desired angle with the outside pipe bending tool.

Consider the removal of the insulation before bending with hydraulic cylinders or bending springs.

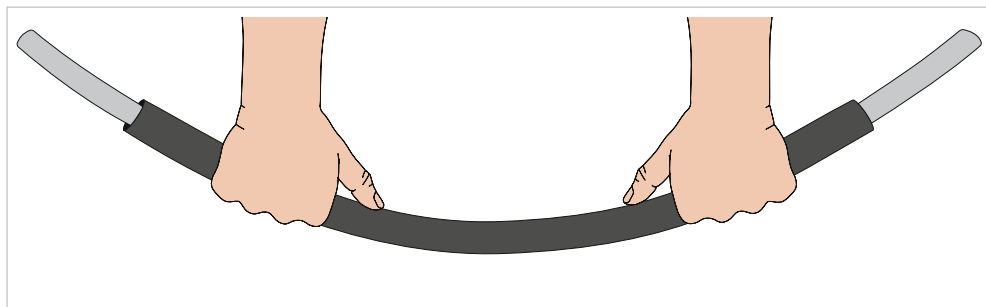

Bending the COOL-FIT 2.0 Push System multilayer composite pipe

Bending radius R	COOL-FIT 2.0 Push System			
d [mm]	16	20	25	32
Bending radius R, with bending spring: $5 \cdot d$ [mm]	80	100	200	-
Bending radius R, with tool: $3.5 \cdot d$ [mm]	56	70	98	112

Minimum bending radius of the COOL-FIT 2.0 Push System pipe

! NOTE! Risk of damaging the pipes due to improper bending!

- Ensure the pipes do not kink when bending them.
- Do not use internal bending springs.

1.4.14 Hoses

Installation of elastomer hoses

To ensure the usability of hose lines and to avoid shortening their service life through additional stresses, please note the following:

- Hose lines must be installed so that their natural position and movement is not hindered.
- During operation, hose lines must in principle not be subjected to external forces such as tension, torsion and compression, unless they have been specially made for the purpose.
- The minimum radius of curvature specified by the manufacturer must be observed.
- Buckling is to be avoided, particularly by the joint.
- Before putting the system into operation, check that the mechanical connections are properly tightened.
- If there is visible external damage, the hose line must not be put into operation.
- The connection fittings should be firmly screwed together.

Proper use of the hose line

- Pressure: do not exceed maximum permitted working pressure and operating vacuum
- Temperature: do not exceed maximum permitted temperature for the medium

Storage

- Store in a cool, dry and dust-free area; avoid direct sunlight or ultraviolet irradiation; protect from nearby heat sources. Piping must not come into contact with substances that can cause damage.
- Hoses and hose assemblies must be stored horizontally, free of tension or bending forces.

1.4.15 COOLING Tool-Box

The GF Piping Systems Cooling Calculation Tool is used to help in the dimensioning and design of cooling systems.

The Cooling Calculation Tool handles:

- Expansion, contraction
- Flexible section design
- Energy savings
- Pipe exterior temperature
- Pipe dimensioning
- Pressure loss
- Dew point/ insulation thickness
- Pipe bracket spacing
- Freezing time
- Weight comparison
- CO₂ footprint

The most common coolants are already stored in the calculation tool. It calculates all system components, such as pipe, fittings and valves. Its menu-based navigation is available in nine languages and allows for efficient and optimized dimensioning of a system. Data for the most commonly used coolants are already stored in the calculation tool. It calculates all system components such as pipe, fittings and valves. The menu is available in nine different languages. It allows system design to be efficient and optimized.

The "comparison" function compares a COOL-FIT system to a steel, stainless steel or copper system.



■ Cooling Calculations Tool: Get it contact to your GF Piping Systems representative or visit www.gfps.com



1.5 Jointing and Installation

1.5.1 Jointing of COOL-FIT 2.0/2.0F

i For general notes and information on electrofusion, see Planning Fundamentals Chapter "Jointing technology", section "Electrofusion joints".

General advice

The quality of a weld is largely determined by careful preparation. The welding surface must be protected from adverse weather conditions such as rain, snow or wind. The permissible temperature range for fusion is -10 °C to 45 °C. National regulations must be observed. In direct sunlight, shielding of the welding area can help to create an even temperature profile around the whole circumference of the pipe. It is particularly important to ensure that the climate conditions are the same for both the electrofusion machine and the welding area.

Executing electrofusion

Protect the welding area

The surfaces to be welded on the pipe and the fitting must be carefully protected from dirt, grease, oils and lubricants. Only cleaning agents suitable for PE must be used.

⚠ No fats (i.e. hand cream, oily rags, silicone, etc.) must be introduced into the fusion zone!

- 1 Without touching the surface, remove product immediately before the installation from packaging

Prepare pipe with stripping and peeling tool for electrofusion welding connection (stripping, peeling and sheath cutting) and check pipe spigot with circumferential measuring tape for compliance with minimum permissible pipe outer diameter.

Minimum permitted pipe external diameter after peeling for COOL-FIT 2.0/2.0F

Temperature (°C)	d nominal diameter (mm)							
	32	40	50	63	75	90	110	140
	d _{min} after peeling (mm)*							
40	31.4	39.4	49.4	62.5	74.5	89.6	109.6	139.7
30	31.3	39.4	49.4	62.4	74.4	89.4	109.5	139.5
20	31.3	39.3	49.3	62.3	74.3	89.3	109.3	139.3
10	31.3	39.2	49.2	62.2	74.2	89.2	109.1	139.1
0	31.2	39.2	49.2	62.1	74.1	89.0	109.0	138.9

* Minimum diameter do not comply with the pipe tolerance specifications for GF electrofusion fittings. COOL-FIT minimum diameter are verified by release tests.

⚠ If the pipe outside diameter falls below the min. permissible value, cut off the spigot and check the blade quality by measuring the chip thickness with a caliper gauge: the reference dimension over the entire length is between 0.2 - 0.4 mm. Replace blade in case of deviation.

⚠ COOL-FIT 2.0 valves and COOL-FIT 2.0 fittings (type B and barrel nipple) need not to be peeled.

2 Cleaning and installation

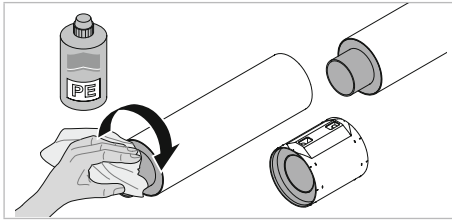

Step 1
Clean the fusion area of the components with PE cleaner and lintfree colourless and clean cloth in circumferential direction.

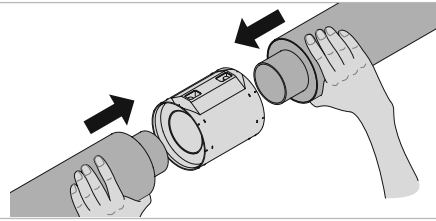

Step 2
Insert pipe in clamping tool and align free of stress. Push fitting up to the limit stop on the pipe.

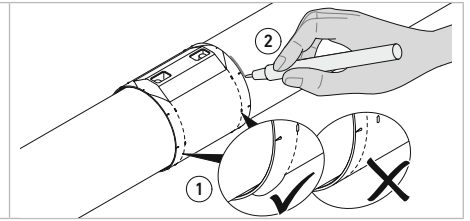

Step 3
Pay attention that the sealing lip arches upwards. Mark end of lip on pipe (to check the change in position during welding).

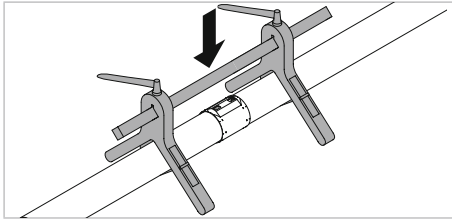

Step 4
Take care for low stress installation and secure the pipe and fitting against dislocation. Tight clamps of clamping tool.

3 Fusion process

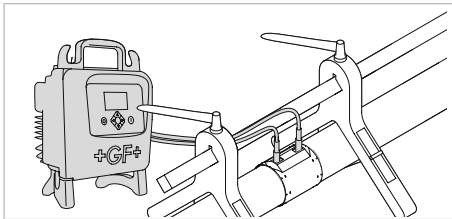

Step 5
Fuse in accordance to the operating instructions of the fusion unit.

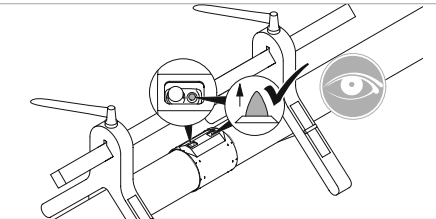

Step 6
During and after fusion, check fusion indicators on the electrofusion fitting and note the messages on the display of the electrofusion machine. Afterwards mark the fitting with following information

- Date
- Welder/ Weld number
- Time at the end of cooling time

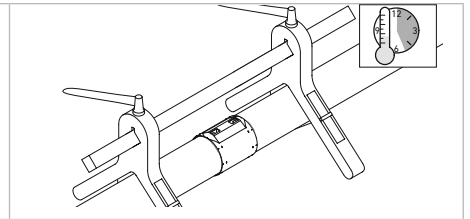

Step 7
Ensure fusion area remains stress free and avoid dislocation until cooling time has elapsed.

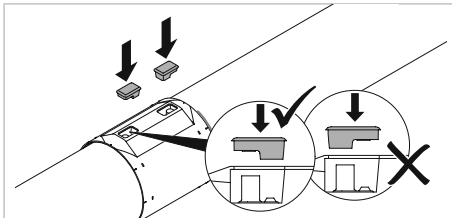

Step 8
After fusion process, fit the insulation of the weld pins onto the fusion contacts and remove retaining device

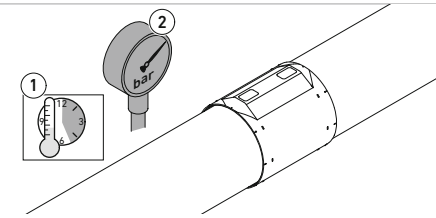

Step 9
After cooling perform pressure tests as per table.

Cooling times before removing retention device and pressure/leak testing

d (mm)	Cooling time before Remove retention device (min.)	Cooling time before internal pressure test at ≤ 6 bar (min.)	Cooling time before internal pressure test at ≤ 18 bar (h)
32	10	15	3
40	10	15	5
50	10	15	4
63	10	20	5
75	15	25	6
90	20	35	8
110	30	35	8
140	45	60	8

The values are valid for pressure tests using a liquid at ≤ 20 ° C. For testing with gas a cooling time of 12 hours is recommended.

Preparation of fitting – remove sealing lip on one side, clean the sealing surfaces

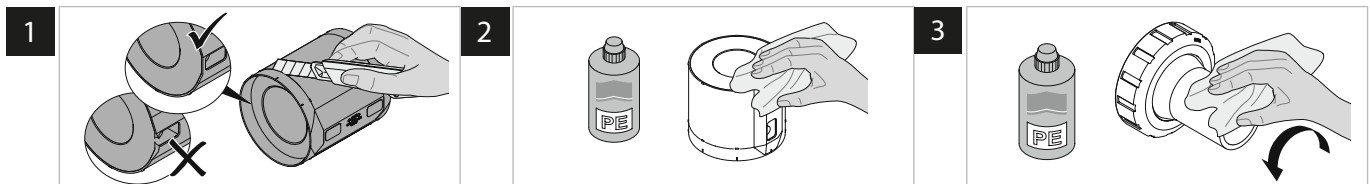

For the jointing to a valve or flange adaptor, the sealing lip of the fitting has to be removed at the valve or flange adaptor side and sealing and fusion surfaces have to be cleaned.

Standard fusion

Fuse both valve ends without valve mounted

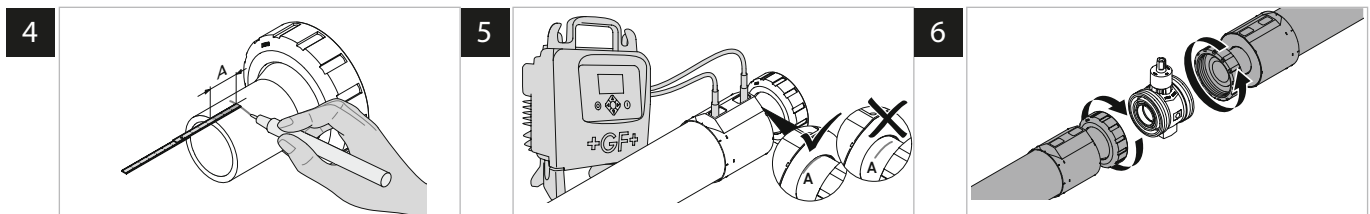

Following insertion depths are valid for COOL-FIT 2.0 components:

d/D (mm)	32/75	40/90	50/90	63/110	75/125	90/140	110/160	140/200
A (mm)	36	40	44	48	55	62	72	84

Mounting the valve insulation

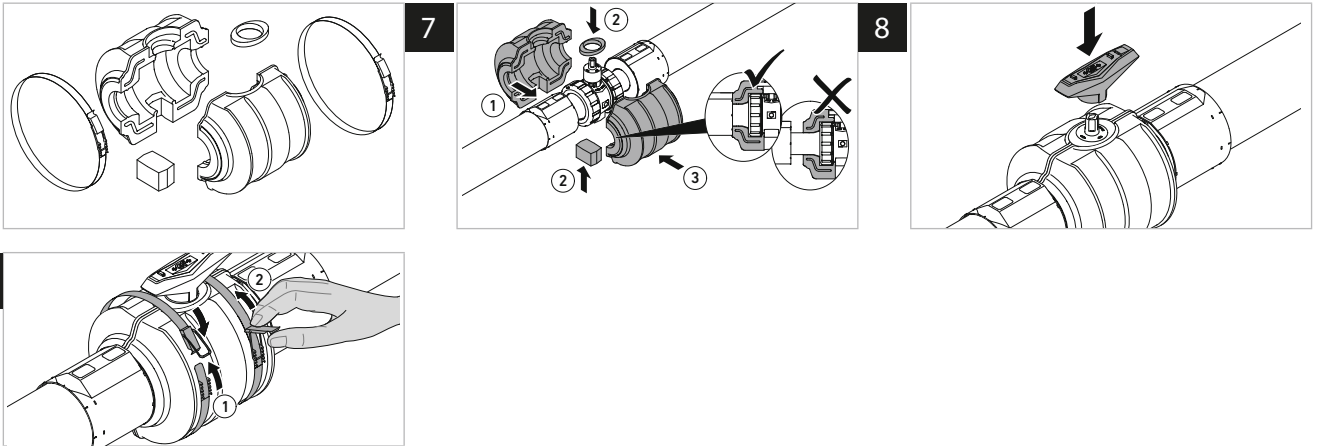

i Further information can be found in the assembly instructions. "Insulation for Ball Valve" and "Insulation for Butterfly Valve and Flange Adapter".

Compact connection fitting-to-fitting

When there is enough space, Fitting-to-Pipe-to-Fitting connections can be realized using a short COOL-FIT 2.0 pipe. The foam removal tool enables the foam removal of pipe lengths of ~110mm for the dimensions d32-d90, or respectively ~170mm for the dimensions d110-d140.

- Shorter connections Fitting-to-Pipe-to-Fitting can be realized using an un-insulated PE100 SDR11 pipe in combination with a piece of insulation that results of a foam removal process of the foam removal tool.

After the peeling of the oxid layer of the un-insulated PE pipe, the insulation ring is pulled over the pipe and the pipe is welded with the fitting.

d	d32	d40	d50	d63	d75	d90	d110	d140
L (mm)	108	120	132	144	165	186	216	252



L : Length of un-insulated PE100 SDR11 pipe needed

For situations with very limited space the sealing lip at the fittings can be removed at the respective side. The jointing of the Fitting-to-Fitting is performed using a barrel nipple, the sealing of the insulation is being done with an adhesive ring which is to be adhered to the cleaned surface of the fittings.

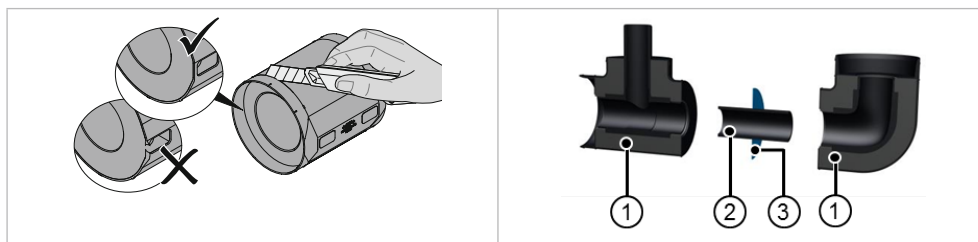

- 1 Fittings
- 2 Barrel nipple
- 3 Adhesive ring

Hoses

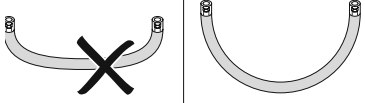
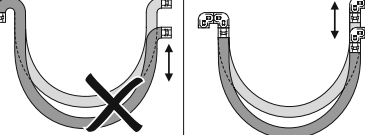
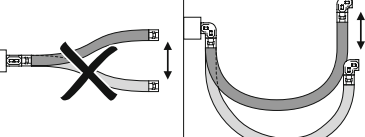
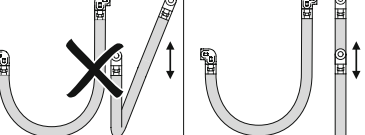
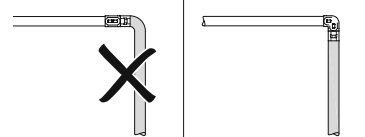
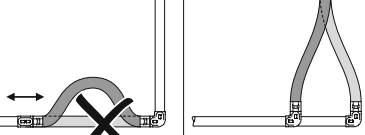
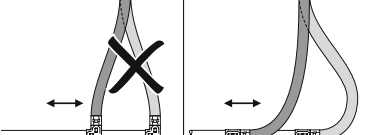
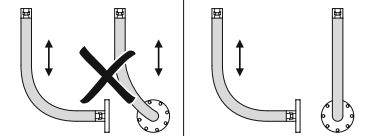
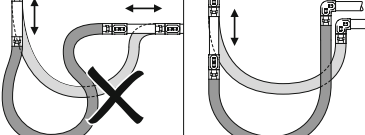
Installation and handling instructions (false/correct)	Description
	<p>Ensure hose is long enough to observe the minimum radius of curvature.</p>
	<p>Avoid excessive bending of hoses, use elbows.</p>
	<p>Avoid fluctuating bending stress and excessive curvature behind the fitting, use elbows.</p>
	<p>Where there is significant axial expansion, the direction of movement and hose axis must lie in the same plane in order to avoid torsion.</p>
	<p>Avoid excessive bending stress by using elbows.</p>
	<p>If the hose absorbs expansion, it must be installed transversally to the direction of expansion.</p>
	<p>For large lateral movements, a 90° angle should be allowed.</p>
	<p>Expansion take-up must be in the plane of the pipe; torsion should be avoided.</p>
	<p>For major axial expansion, the pipe must be installed in a U-shape to avoid kinking.</p>

Transition Fittings

The GF Piping Systems range of fittings provides a variety of transitions and threaded fittings to connect plastic piping components to pipe, fittings or valves in metal (or vice versa). The metal threads Rp and R can be sealed with hemp or PTFE tape as long as the counterpart is not made of plastic. Male and female G threads must be sealed with flat gaskets. The advantage of a threaded G connection is radial and torsion-free possibility for installing and uninstalling.

Next to the traditional transition to metal piping, these fittings can also be used to connect a manometers.



To prevent electrochemical corrosion, stainless steel connecting elements should preferably be used for steel transitions and brass connecting elements for transitions to non-ferrous metals.

Combining G and R threads

The connection of a male parallel pipe thread G in accordance with EN ISO 228-1, with a female parallel pipe thread Rp in accordance with ISO 7-1 is not intended according to standards. A tight connection is possible under favorable conditions, but cannot be established reliably.

Connecting the insulations of Transition Fittings and jointing elements of Flexible Hoses

The NBR insulation of the COOL-FIT 2.0 Transition Fittings is applied following the jointing of the COOL-FIT 2.0 Transition Fittings with the COOL-FIT 2.0 Fitting Type A, and the mechanical jointing of the threaded components of Hose and Transition Fitting. The NBR insulation of Transition Fittings is supplied with axial adhesive tapes. The adhesive tapes are used for a condensation proof axial sealing of the NBR insulation. The radial jointing of the jointing face of the NBR insulation can be applied either by adhesive cement or by adhesive tape.

On joining transition fittings to flexible hoses, the insulation of the flexible hoses can be jointed directly at the COOL-FIT electrofusion fitting using adhesive cement or adhesive tape.

Jointing Instructions for the adhesive cement

The adhesive should be thoroughly stirred before use. A thin film is applied by means of the brush to both surfaces to be bonded. Doing this, the consumption is ~0.2 – 0.25kg/m².

The open joint time is about 3:15 minutes depending on temperature and humidity of air.

Before the coated surfaces are brought together the, the adhesive must still be tacky but should not transfer to the skin when finger-tested. The surfaces should be brought together quickly and firmly and should be held together for a few seconds.

The recommended temperature and for storage and processing is in the range between +15°C and 25°C. The adhesive should not be used below +10°C.

Flange connections

Flanges with sufficient thermal and mechanical stability must be used. The different flange types by GF Piping Systems fulfill these requirements. The gasket dimensions must match the outer and inner diameter of the flange adaptor or valve end. Differences between the inner diameters of gasket and flange that are higher than 10 mm may result in malfunctioning flange connections.

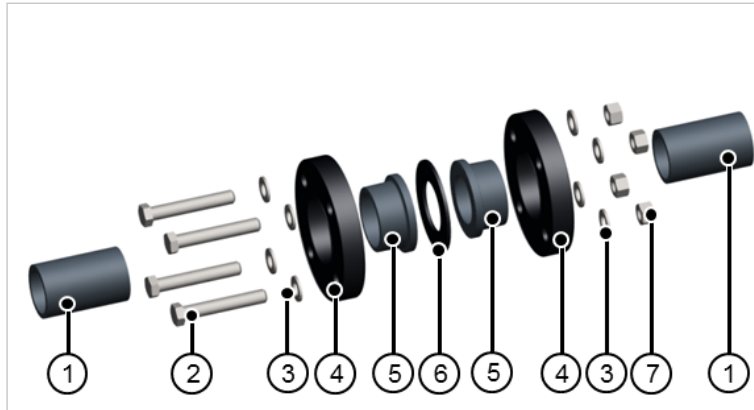

- 1 Pipe
- 2 Bolt
- 3 Washer
- 4 Backing Flange
- 5 Flange Adaptor/ Valve end
- 6 Flange gasket
- 7 Nut

Comparison of flange connections

Flange connection	Properties
PP-V flange	<ul style="list-style-type: none"> • Corrosion-free all-plastic flange made of polypropylene PP-GF30 (fiber-glass reinforced) • High chemical resistance (hydrolysis-resistant) • Maximum possible break resistance due to elasticity (deforms if it is tightened too much) • Use for ambient temperatures up to 80 °C • UV-stabilized • With integrated bolt-fixing • Self-centering aid of the backing flange on the flange adaptor • Symmetric design allows assembly on either side: A "reverse" installation is never possible. All important information is readable • V-groove (patented) • Even distribution of forces across the backing flange (conserves components) • Supports a longer-lasting torque for a safe joint
PP-steel flange	<ul style="list-style-type: none"> • Very robust and stiff due to the steel inlay • Corrosion-free plastic flange made of polypropylene PP-GF30 (fiber-glass reinforced) with steel inlay • High chemical resistance (hydrolysis-resistant) • Maximum ambient temperature 80 °C • UV-stabilized

Creating flange joints

When executing flange joints, the following points should be noted:

Orientation of bolts beyond the two main axes

- For horizontal pipings systems, the orientation shown of the bolts beyond the main axes (see the following figure) is preferred since possible leaks at the flange connection do not cause the medium to run directly onto the bolts.

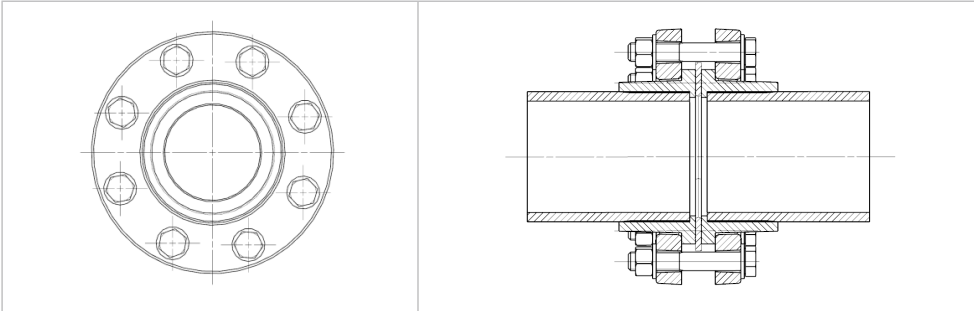

Flange with main axes (centered crosswise)

- Flange adaptor, valve end or fixed flange, seal and loose flange must be aligned centrally on the pipe axis.
- Before tightening the screws, the sealing surfaces must be aligned parallel and snug against the seal. Tightening misaligned flanges with the resulting tensile stress is to be avoided at all costs.

Selecting and handling bolts

- The length of the bolts should be in such a way that the bolt thread does not protrude more than 2-3 turns of the thread at the nut. Washers must be used at the bolts as well as the nut. If too long bolts are used it's not possible to mount the insulation half shells afterwards.
- To ensure that the connecting bolts can be easily tightened and removed after a lengthy period of use, the thread should be lubricated, e.g. with molybdenum sulphide.
- Tightening the bolts by using a torque wrench.
- The bolts must be tightened diagonally and evenly: First, tighten the bolts by hand so that the gasket is evenly contacting the jointing faces. Then tighten all bolts diagonally to 50 % of the required torque, followed by 100 % of the required torque. The recommended bolt tightening torques are listed in the following table. However, deviations may occur in practice, e.g. through the use of stiff bolts or pipe axes that are not aligned. The Shore hardness of the gasket can also influence the necessary tightening torque.
- In practice, deviations from this may occur, e.g. due to the use of difficult screws that are difficult to turn or due to non-aligned pipe axes. The Shore hardness of the seal also influences the necessary tightening force.
- We recommend checking the tightening torques 24 hours after assembly according to the specified values and, if necessary, retighten them. Always tighten diagonally here, as well.
- After the pressure test, the tightening torques must be checked in any case and, if necessary, retightened.

i For more information on flanges, see DVS 2210-1 supplement 3.

i In the area of flexible sections and expansion loops, no bolt connections or flange connections should be used since the bending stress may cause leaks.

Bolt tightening torque guidelines for metric (ISO) flange connections with PP-V and PP- steel flanges

The indicated torques are recommended by GF Piping systems. These torques already ensure a sufficient tightness of the flange connection. They deviate from the data in the DVS 2210-1 Supplement 3, which are to be understood as upper limits. The individual components of the flange connection (valve ends, flange adapters, flanges) by GF Piping systems are dimensioned for these upper limits.

Pipe outside diameter d (mm)	Nominal Diameter DN (mm)	Tightening torque		
		MD (Nm)	Flat ring maximum pressure 10 bar / 40 ° C	Profile seal maximum pressure 16 bar
d32	DN25	15	10	10
d40	DN32	20	15	15
d50	DN40	25	15	15
d63	DN50	35	20	20
d75	DN65	50	25	25
d90	DN80	30	15	15
d110, 125	DN100	35	20	20
d140	DN125	45	25	25

Length of bolts

In practice, it is often difficult to determine the correct bolt length for flange joints. It can be derived from the following parameters:

- Thickness of the washer (2x)
- Thickness of the nut (1x)
- Thickness of the gasket (1x)
- Flange thickness (2x)
- Thickness of flange collar (valve end or flange adaptor) (2x)
- Valve installation length, if applicable (1x)

In order to ensure the fitting of the insulation half shells of the COOL-FIT 2.0 flange adaptors the used bolts must not be too long.

The following table is useful in determining the necessary bolt length.

i Under DVS 2210-1, the screw length should be such that it extends 2 to 3 threads beyond the nut.

■ Online "screw lengths and tightening torques" tool on www.gfps.com/tools



For a COOL-FIT 2.0 Flange adaptors used together with PP-Steel backing flanges, the following bolt lengths can be used.

Dimension	d32	d40	d50	d63	d75	d90	d110	d140
Screws	M12x80	M16x80	M16x90	M16x90 or M16x100	M16x100	M16x100	M16x100	M16x130

Installation fittings (for sensors)

Transitions and threaded plastic fittings should first be screwed finger tight. The fittings are then screwed in using an appropriate tool until 1 or 2 threads remain visible.

GF Piping Systems recommends using PTFE tape to seal transitions and threaded plastic fittings. Alternatively, Henkel Tangit Uni-Lock or Loctite 55 thread seal or Loctite 5331 thread sealant gel can be used. Follow the manufacturer's instructions. When using other sealants, you must check compatibility with the plastic used.

On installing Installation fittings in horizontal piping systems, the sensors should be in 1 – 5 or 7 – 11 clock position.

⚠ Do not use hemp! It may swell up, putting force on the plastic fittings and damaging plastic threads. Hemp is also not resistant to chemicals used in some media.

Installation of COOL-FIT 2.0 fixed points

The COOL-FIT pipe shall be installed with a standard fix point as shown below.

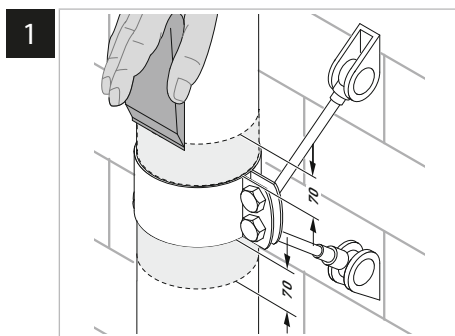

Step 1
Remove the outer layer of the PE jacket with a pipe scraper

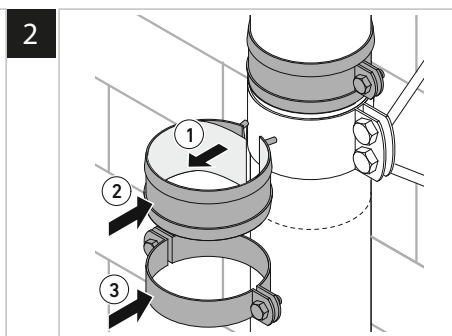

Step 2
Remove the yellow protection band from the welding bands and place them on the COOL-FIT pipe. Fix the welding bands with the pipe clips provided.

Note: The necessary welding pressure on the clean and dry COOL-FIT pipe is achieved by tightening the pipe clips. Take care that between fixed point clip and weld band there are no visible holes.

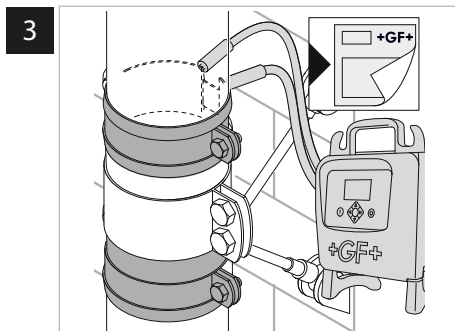

Step 3
Bond the welding band with the COOL-FIT pipe in accordance with the operating instructions of the electrofusion machine. Use welding adaptors of the y-cable with integrated welding adaptors for the bonding.

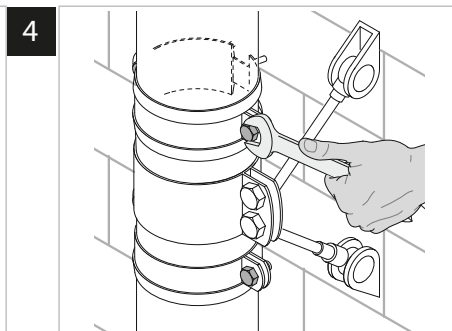

Step 4
Retighten the pipe clips after 10 minutes.

Installation of COOL-FIT 2.0F fixed points

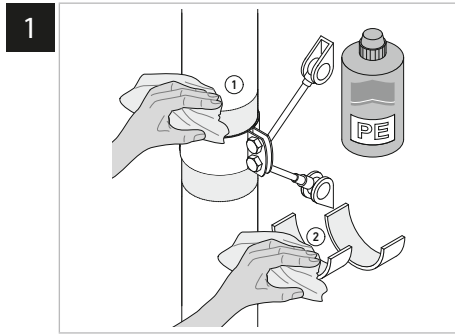

Step 1
Clean the cementing area on the pipe and the components with Tangit PE cleaner and lintfree colourless and clean cloth in circumferential direction.

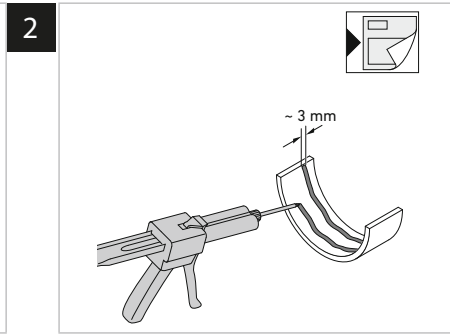

Step 2
Place the Tagit RAPID in about 3mm stripes on the inner side of the fixed point set half shells.

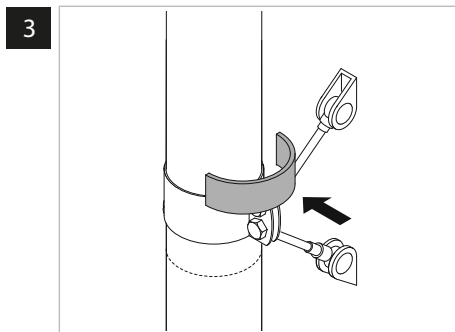

Step 3
Cement the half shells on the pipe next to the pipe clamp.

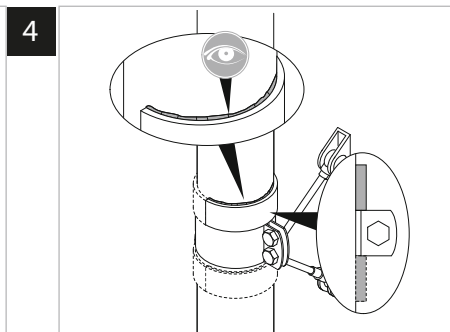

Step 4
Check the cementing and ensure the fixed point half shells are next to the pipe clamp.

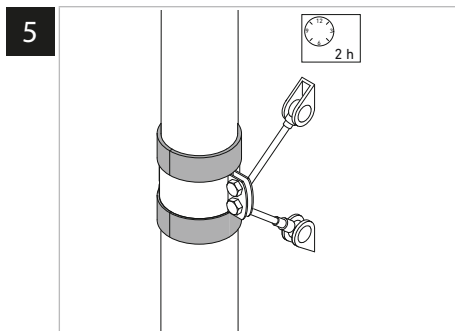

Step 5
Let the fixed point dry for minimum 2hours.

1.5.2 Jointing of COOL-FIT 2.0 Push System

General advice

The push-in fittings may only be installed by skilled personnel who have been regularly instructed in work safety and environmental protection on pressurized pipes. The quality of the mechanical connection is largely determined by the careful execution of the preparatory work. The mating area must be protected from adverse weather conditions such as rain, snow or wind. Permissible temperature range for processing is -10 °C to +45 °C. The national guidelines must be observed.

The surfaces to be welded on the pipe and fitting must be carefully protected from dirt, any grease, oil and lubricants. Only cleaning agents suitable for PE may be used.

Work preparation

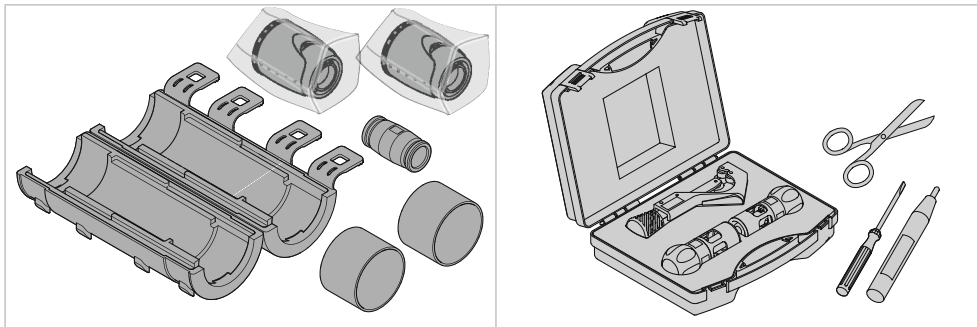

Remove products from packaging immediately before assembly and have necessary tools ready.

Prepare pipe

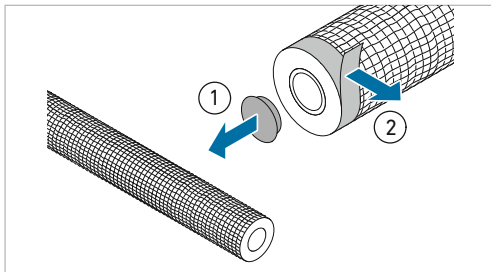

Step A

For new pipe start: Remove cap from pipe end and remove tape from insulation.

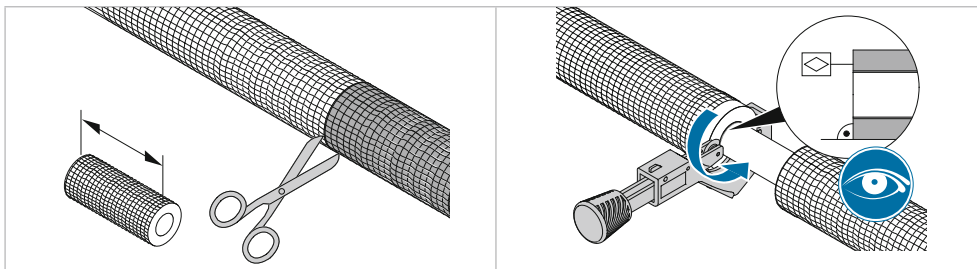

Step B

Pipe lengths: Cut the insulation at right angles at the interface using scissors. Push the insulation aside and cut the pipe flush with the insulation using a pipe cutter.

Joint

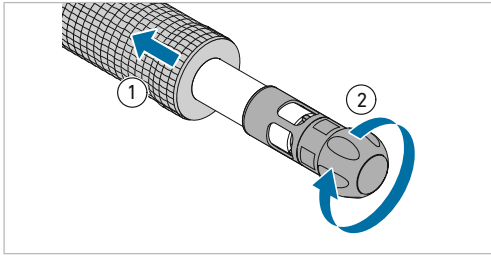

Step 1

Push back the insulation and chamfer and calibrate the tube end with the chamfering tool. Visually check the chamfering. Remove any chips that may be adhering, also inside the tube.

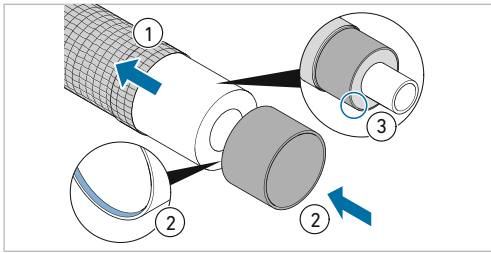

Step 2

Pull the net of the insulation to the rear. Push the ring over the insulation with the chamfered side first. The surface of the insulation must lie flush in the ring.

i It is easier to attach the ring if the insulation is first pulled off the pipe, then the ring is slid over the insulation. Then both are pushed back over the pipe.

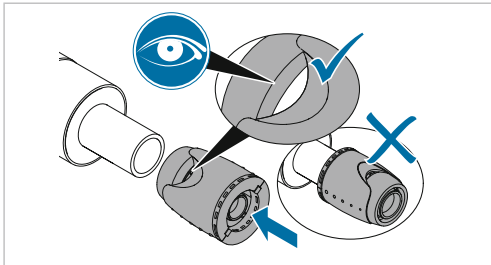

Step 3

The adapters are packaged individually. The packaging is only opened immediately before use.

Push the adapter onto the tube end as far as it will go. Visually check that the viewing window of the adapter is completely filled by the tube.

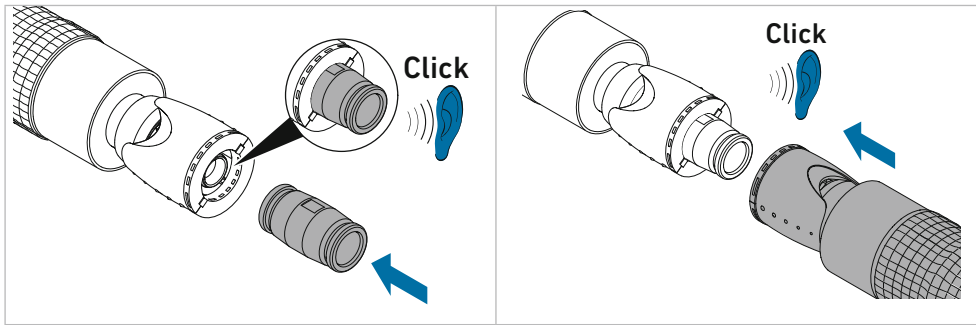

Step 4- 5

Insert the module into the adapter and push it in until an audible click is heard (acoustic check). Prepare the second tube end and also push it onto the module until an audible click is heard.

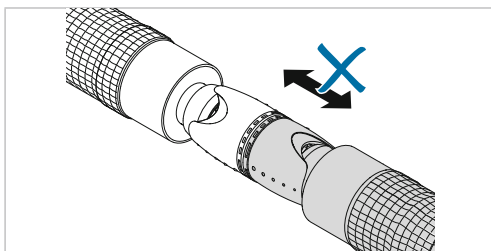

Step 6

Check by counter-tensioning whether the tube adapter and module are firmly connected to each other.

During the counter-tension test, the adapter and module may slide apart by up to 5 mm. Due to the dynamic holding mechanism, the pipe moves back slightly during operation or during the pressure test. This is not a defect of the assembly from a technical point of view.

Insert joint into shell

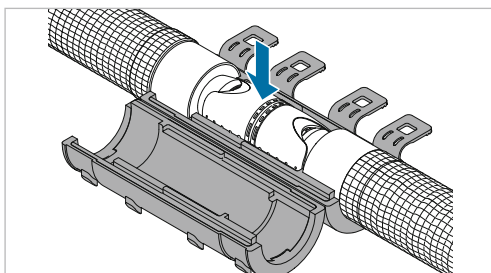

Step 7

Insulation with ring is pushed to butt against the adapter. The net must be outside the shell.

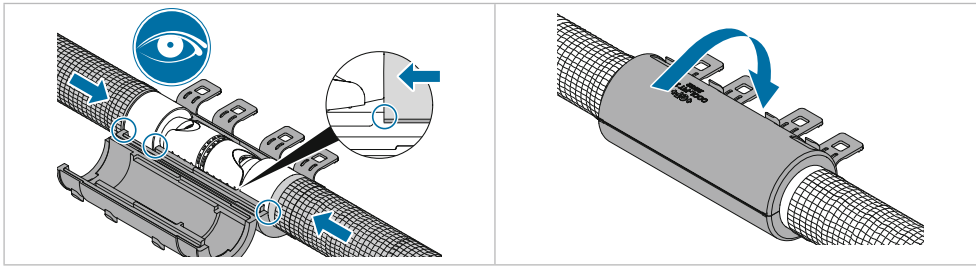

Step 8 - 9

Visually check that the insulation is butted in the shell and, if necessary, push the adapter into place. The ring must be completely in the shell. Then close the shell.

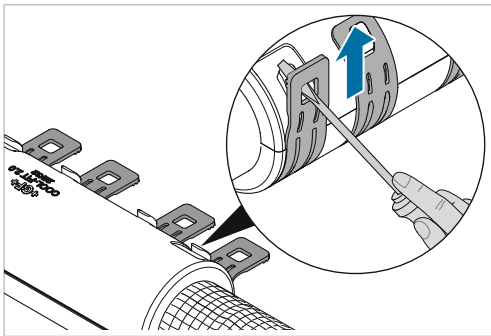

Step 10

Close the tabs with a screwdriver.

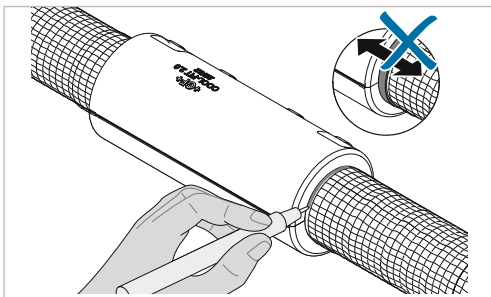

Step 11

After closing the shell, a mark is placed along the edge of the shell. The mark indicates whether the insulation has shifted during the further installation process. If the mark is no longer visible along the shell, the shell must be reopened and checked.

Disassembly

Fitting

The fitting can be opened and released again.

i **NOTE!** Loss of warranty if adapters are opened!
 If adapters have been opened, e.g. during disassembly, the warranty is no longer valid.
 → Do not reuse opened adapters.

Shell

The shell can be opened at the tabs and reused.

Plug connection

It is possible to loosen the connection, but the adapter will be destroyed in the process.

i **NOTE!** Destruction of the adapter by loosening the connection.
 Loosening the connection is possible, but the adapter will be destroyed in the process.
 → For the next assembly: Use a new adapter.

1. Use water pump pliers to fix the collar of the half shells. Use a second pair of water pump pliers to loosen the adapter housing in an anticlockwise direction.
2. This destroys the housing and it must not be used again.
3. Unscrew the adapter housing completely.
4. Pull the tube off the support nipple.
5. Remove the adapter housing, support ring and toothed ring from the tube.
6. Remove the half shells of the adapter from the support nipple of the module.
7. Pull the support nipple of the adapter out of the module.
8. Loosen the clamping ring by squeezing it lightly with pliers and remove it from the tube.
9. Dispose of all parts of the dismantled adapter properly.

Module

The module can be reused.

The tube end must be shortened by 6 mm (this complies with the insertion depth of the toothed ring) and recalibrated.

1.5.3 Pressure test

Internal pressure test

For internal pressure testing and commissioning, the same conditions apply for COOL-FIT 2.0 / 2.0F as for the non-insulated ecoFIT system (PE).

1.5.4 Internal pressure and leak testing

Introduction to the pressure test

Overview of the various test methods

Leakage test	Inner Pressure test		Leakage test	
Medium	Water	Gas ¹	Compressed air ¹	Gas/air (oil-free)
Type	Incompressible	Compressible	Compressible	Compressible
Test pressure (overpressure)	P_p (perm) or $0.85 \bullet P_p$ (perm)	Operating pressure 2 bar	Operating pressure 2 bar	0.5 bar

¹ Observe the applicable safety precautions. More information is available in DVS 2210-1 addendum 2.

Leakage test	Inner Pressure test			Leakage test
Potential risk during the pressure test	Low	High	High	Low
Significance	High: Proof of pressure resistance incl. impermeability to test medium	High: Proof of pressure resistance incl. impermeability to test medium	High: Proof of pressure resistance incl. impermeability to test medium	Gering

A number of international and national standards and guidelines are available for leak and pressure tests. Therefore, it is often not easy to find the applicable test procedure and for example the test pressure.

The purpose of a pressure test is:

- Ensure the resistance to pressure of the piping system, and
- Show the leak-tightness against the test medium

Usually, the internal pressure test is done as a water pressure test and only in exceptional cases (under consideration of special safety precautions) as a gas pressure test with air or nitrogen.

Water is an incompressible medium. In case of a leakage during the pressure test relative low energy is set free. Therefore the hazard potential is significantly lower compared to testing with a compressible medium like e.g. compressed air.

Internal pressure test with water or similar incompressible test medium

The internal pressure test is done when installation work has been completed and presupposes an operational piping system or operational test sections. The test pressure load is intended to furnish experimental proof of operational safety. The test pressure is not based on the operating pressure, but rather on the internal pressure load capacity, based on the pipe wall thickness.

Addendum 2 of DVS 2210-1 forms the basis for the following information. This replaces the data in DVS 2210-1 entirely. The modifications became necessary because the reference value "nominal pressure (PN)" is being used less and less to determine the test pressure (1.5 x PN, or 1.3 x PN) and is being replaced by SDR. In addition, a short-term overload or even a reduction in the service life can occur if the pipe wall temperature $T_R = 20\text{ °C}$ is exceeded by more than 5 °C in the course of the internal pressure test based on the nominal pressure.

Test pressures are, therefore, determined in relation to SDR and the pipe wall temperature. The 100-h value from the long-term behavior diagram is used for the test pressure.

Test parameters

The following table provides recommendations on the performance of the internal pressure test

Purpose	Preliminary Review	Main examination
Test pressure p_p (depends on the pipe wall temperature and the permitted test pressure of the installed components, see "determination of the test pressure")	$\leq P_{p(zul)}$	$\leq 0.85 P_{p(zul)}$
Test duration (depends on the length of the pipe sections)	L \leq 100 m: 3 hrs 100 m < L \leq 500 m: 6 hrs	L \leq 100 m: 3 hrs 100 m < L \leq 500 m: 6 hrs
Checks during the test (test pressure and temperature curves must be recorded)	At least 3 checks distributed across the test period with test pressure restored	At least 3 checks distributed across the test period without restoring the test pressure

Pre-test

The pre-test serves to prepare the piping system for the actual test (main test). In the course of pre-testing, a tension-expansion equilibrium in relation to an increase in volume will develop in the piping system. A material related drop in pressure will occur which will require repeated pumping to restore the test pressure and also frequently a re-tightening of the flange connection bolts.

The guidelines for an expansion-related pressure decrease in pipe are:

Material	Pressure drop (bar/h)
COOL-FIT 2.0 / 2.0F	1.2

Main test

In the context of the main test, a much smaller drop in pressure can be expected at constant pipe wall temperatures so that it is not necessary to pump again. The checks can focus primarily on leak detection at the flange joints and any position changes of the pipe.

Observe if using compensators

If the piping system to be tested contains compensators, it has an influence on the expected axial forces on the fixed points of the piping system. Because the test pressure is higher than the operating pressure, the axial forces on the fixed points increase proportionately. This has to be taken into account when designing the fixed points.

Observe if using valves

When using a valve at the end of a piping system (end or final valve), the valve and the pipe end should be closed by a dummy flange or cap. This prevents an inadvertent opening of the valve and release of the medium.

Filling the pipe

Before starting the pressure test, the following points should be checked:

1. The installation has been carried out in accordance with its plans.
2. All pressure relief and check valves are fitted in the direction of flow.
3. All end valves have been closed.
4. All valves for devices have been closed to secure against pressure.
5. A visual inspection has been made of all connections, pumps, measurement devices and tanks.
6. The waiting time after the last weld or bond has been observed

Now the piping system can be filled from the geodetic lowest point. Special attention should be given to the air vent. If possible, vents should be provided at all the high points of the piping system and these should be open when filling the system. Flushing velocity should be at least 1 m/s.

Reference values for the filling volume are given in the table below.

d (mm)	V (l/s)
≤ 90	0.15
110	0.3
140	0.7

Allow sufficient time to pass between filling and testing the pipe for the air in the piping system to escape through the vents: about 6 to 12 hours, depending on nominal diameter.

Applying the test pressure

The test pressure is applied in accordance with this diagram. It is important to ensure that the rate of pressure increase does not cause any water hammers.

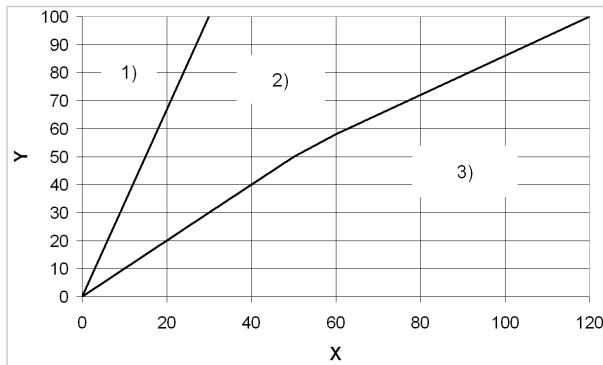

- Y Test pressure (%)
- X Time of test pressure increase (min)
- 1) Rate of pressure increase up to DN100 mm
- 2) Range of pressure increase rates between DN100 and DN400 mm
- 3) Guideline rate of pressure increase for DN500 and higher: 500/DN (bar/10 min)

Determination of the test pressure

The permissible test pressure is calculated using the following formula:

$$P_{p(zul)} = \frac{1}{SDR} \cdot \frac{20 \cdot \sigma_{v(T, 100 h)}}{S_p \cdot A_G}$$

- $\sigma_{v(T, 100 h)}$ Creep strength for the pipe wall temperature
- S_p Minimum safety factor for creep strength
- A_G Processing method or geometry specific factor which reduces the permissible test pressure
- T_R Pipe metal temperature: mean temperature of test medium and pipe surface

Material	Sp minimum safety factor
PE100	1.25
PVC-U	2.5

To make things easier, the permissible test pressures can be taken directly from the following diagrams.

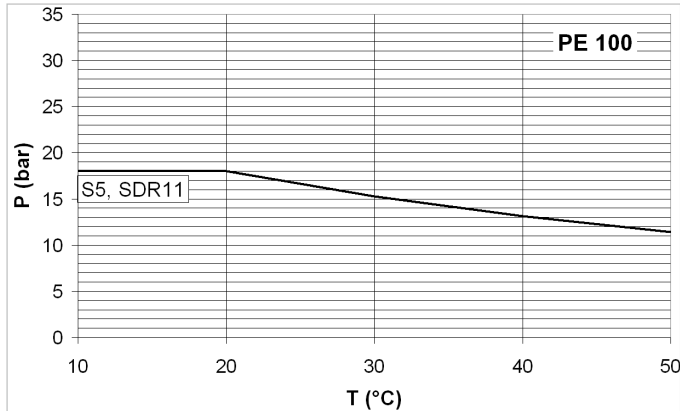

P permitted test pressure (bar)
T pipe wall temperature (°C)

Checks during testing

The following measurement values must be recorded consistently during testing:

8. Internal pressure at the absolute lowest point of the piping system
9. Medium and ambient temperature
10. Water volume input
11. Water volume output
12. Pressure drop rates

1.5.5 Start-up with secondary coolants

Secondary coolants such as glycol solutions must only be introduced in liquid, pre-mixed form into COOL-FIT 2.0 piping systems. Filling should be performed slowly from the lowest point of the system to allow the piping system to vent at its highest point.

Filling and Venting

It is important to vent air from all piping systems. This is particularly important with saline solutions, because of their corrosive properties. Venting process:

- The system must be filled slowly.
- Manual or automatic venting devices must be fitted at the highest point of the system.
- Long horizontal lines should be installed at a slight gradient.
- The piping layout should be chosen in such a way as to prevent the formation of air pockets.
- Installation of an air vent with a medium column as a reserve.
- Follow the specific manufacturer instructions for the liquids as regards filling

1.6 Transport, Handling and Storage

1.6.1 Transport

On trucks/in crates, manual transport.

For hygienic reasons, all openings on pipes, fittings and valves must be closed until final assembly.

- Protect the product against external force (impact, shock, vibration, etc.) during transport.
- Transport and/or store product in unopened original packaging.
- Protect the product from dust, dirt, moisture, heat and UV radiation.
- Make sure that the product is not damaged by mechanical or thermal influences.
- Check the product for transport damage before assembly.

1.6.2 Storage

All plastic pipe including pre-insulated plastic pipe such as COOL-FIT 2.0 must be stacked on a flat surface with no sharp edges. During handling, care must be taken to avoid damage to the external surface of the pipe, i.e. by dragging along the ground). Pipe should not cross over each other in storage as this is likely to cause bending.

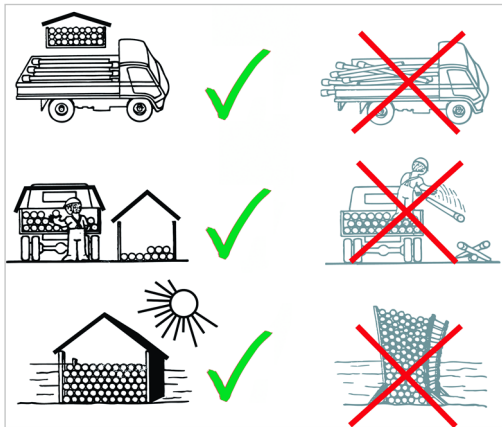

1.7 Environment

The materials used for COOL-FIT 2.0 are suitable for recycling. GF Piping Systems aims to satisfy its customer's wishes concerning environmental aspects.

i For more information at www.coolfit.georgfischer.com

1.7.1 Disposal

i Country-specific regulations

Disposal and recycling may be regulated differently in different countries by laws, directives, ordinances, standards, regulations and instruction leaflets.

When disposing of or recycling the product, the single components and the packaging, the locally applicable regulations must be observed.

Local support around the world

Visit our webpage to get in touch with your local specialist:
www.gfps.com/our-locations



The information and technical data (altogether "Data") herein are not binding, unless explicitly confirmed in writing.
The Data neither constitutes any expressed, implied or warranted characteristics, nor guaranteed properties or a guaranteed durability. All Data is subject to modification. The General Terms and Conditions of Sale of Georg Fischer Piping Systems apply.